



SmartWave™
Switching
Amplifier

Operation Manual

This manual covers models:

SW 5550AE

SW 3700AE

SW 1850AE

ELGAR ELECTRONICS CORPORATION

9250 Brown Deer Road

San Diego, CA 92121-2294

1-800-733-5427

Tel: (858) 450-0085

Fax: (858) 458-0267

Email: sales@elgar.com

www.elgar.com

©2002 by Elgar Electronics Corporation

This document contains information proprietary to Elgar Electronics Corporation. The information contained herein is not to be duplicated or transferred in any manner without prior written permission from Elgar Electronics Corporation.

ELGAR ONE-YEAR WARRANTY

Elgar Electronics Corporation (hereinafter referred to as Elgar) warrants its products to be free from defects in material and workmanship. This product warranty is effective for one year from the date of shipment to the original purchaser. Liability of Elgar under this warranty shall exist provided that:

- the Buyer exposes the product to normal use and service and provides normal maintenance on the product;
- Elgar is promptly notified of defects by the Buyer and that notification occurs within the warranty period;
- the Buyer receives a Return Material Authorization (RMA) number from Elgar's Customer Service Department prior to the return of the product to Elgar for repair, phone 800-73-ELGAR (800-733-5427), ext. 2295;
- the Buyer returns the defective product in the original, or equivalent, shipping container;
- if, upon examination of such product by Elgar it is disclosed that, in fact, a defect in materials and/or workmanship does exist, that the defect in the product was not caused by improper conditions, misuse, or negligence; and,
- that Elgar markings and nameplates have not been altered or removed and the equipment has not been repaired or modified by anyone other than Elgar authorized personnel.

This warranty is exclusive and in lieu of all other warranties, expressed or implied, including, but not limited to, implied warranties of merchantability and fitness of the product to a particular purpose. Elgar, its agents, or representatives, shall in no circumstance be liable for any direct, indirect, special, penal, or consequential loss or damage of any nature resulting from the malfunction of the product. Remedies under this warranty are expressly limited to repair or replacement of the product.

CONDITIONS OF WARRANTY

- To return a defective product, contact an Elgar representative or the Elgar factory for an RMA number. Unauthorized returns will not be accepted and will be returned at the shipper's expense.
- For Elgar products found to be defective within thirty days of receipt by the original purchaser, Elgar will absorb all ground freight charges for the repair. Products found defective within the warranty period, but beyond the initial thirty-day period, should be returned prepaid to Elgar for repair.
- Normal warranty service is performed by Elgar during the weekday hours of 7:30 am to 4:30 pm Pacific time. Warranty repair work requested to be accomplished outside of normal working hours will be subject to Elgar non-warranty service rates.
- Warranty field service is available on an emergency basis. Travel expenses (travel time, per diem expense, and related air fare) are the responsibility of the Buyer. A Buyer purchase order is required by Elgar prior to scheduling.
- A product found, upon inspection by Elgar, to be in specification is subject to an inspection fee and applicable freight charges.
- Equipment purchased in the United States carries only a United States warranty for which repair must be accomplished at the Elgar factory.



Committed to Quality...Striving for Excellence

This page intentionally left blank.

SAFETY NOTICE

Before applying power to the system, verify that the SW Series unit is configured properly for the user's particular application.



WARNING!

Hazardous voltages in excess of 280 VRMS, 600V peak may be present when covers are removed. Qualified personnel must use extreme caution when servicing this equipment. Circuit boards, test points, and output voltages may be floating above (below) chassis ground.

Installation and service must be performed by qualified personnel who are aware of dealing with attendant hazards. This includes such simple tasks as fuse verification.

Ensure that the AC power line ground is connected properly to the SW Series unit input connector or chassis. Similarly, other power ground lines including those to application and maintenance equipment must be grounded properly for both personnel and equipment safety.

Always ensure that facility AC input power is de-energized prior to connecting or disconnecting the input/output power cables.



During normal operation, the operator does not have access to hazardous voltages within the chassis. However, depending on the user's application configuration, HIGH VOLTAGES HAZARDOUS TO HUMAN SAFETY may be generated normally on the output terminals. Ensure that the output power lines are labeled properly as to the safety hazards and that any inadvertent contact with hazardous voltages is eliminated. To guard against risk of electrical shock during open cover checks, do not touch any portion of the electrical circuits. Even when the power is off, capacitors can retain an electrical charge. Use safety glasses during open cover checks to avoid personal injury by any sudden failure of a component.

Due to filtering, the unit has high leakage current to the chassis. Therefore, it is essential to operate this unit with a safety ground.

Some circuits are live even with the front panel switch turned off. Service, fuse verification, and connection of wiring to the chassis must be accomplished at least five minutes after power has been removed via external means; all circuits and/or terminals to be touched must be safety grounded to the chassis.

After the unit has been operating for some time, the metal near the rear of the unit may be hot enough to cause injury. Let the unit cool before handling.

Qualified service personnel need to be aware that some heat sinks are not at ground, but at high potential.



CAUTION!

380V 3-phase input power systems (4-wire) must have a neutral connection. (For units built before June 2004: the neutral must not be switched. Apply neutral before phase voltage or serious damage to the equipment may result).

For safe operation, it is required that output power neutral be connected to chassis ground. The SW system is shipped with a ground wire between power neutral and chassis ground.

These operating instructions form an integral part of the equipment and must be available to the operating personnel at all times. All the safety instructions and advice notes are to be followed.

Neither Elgar, San Diego, California, USA, nor any of the subsidiary sales organizations can accept any responsibility for personal, material or consequential injury, loss or damage that results from improper use of the equipment and accessories.

SAFETY SYMBOLS



CAUTION
Risk of Electrical Shock



CAUTION
Refer to Accompanying Documents



Off (Supply)



Direct Current (DC)



Standby (Supply)



Alternating Current (AC)



On (Supply)



Three-Phase Alternating Current



Protective Conductor Terminal



Earth (Ground) Terminal



Fuse



Chassis Ground

CONTENTS

SECTION 1 GENERAL DESCRIPTION

1.1	Introduction.....	1-1
1.2	Input Specifications	1-2
1.3	Output Specifications: IEC Test Modes	1-3
1.4	Waveform Specifications	1-4
1.5	Interharmonics Waveform Generator (Optional).....	1-5
1.6	Protection and Safety	1-5
1.7	Agency Requirements	1-6
1.8	Physical Specifications (All Models)	1-6
1.9	Environmental Data	1-6
1.10	Other Standard Features	1-7
1.11	Options	1-8
1.12	Glossary of Technical Terms	1-9
	1.12.1 IEC Test Modes	1-9
	1.12.2 Interharmonic Waveform Generator (IWG)	1-9

SECTION 2 INSTALLATION

2.1	Introduction.....	2-1
2.2	Unpacking.....	2-1
2.3	Pre-Installation Inspection	2-2
2.4	Installation	2-2
2.5	Air Intake and Exhaust.....	2-2
2.6	Installation/Dimensional Drawing.....	2-3

2.7	Input/Output Connectors	2-6
2.7.1	BNC Connectors	2-7
2.7.2	EXT IN (External Input).....	2-7
2.7.3	DFI (Direct Fault Indicator)	2-8
2.7.4	IEEE 488.2.....	2-9
2.7.5	Slave Connector	2-9
2.7.6	Grounding.....	2-10
2.8	Input Power Requirements.....	2-10
2.8.1	187 to 264 VRMS 3-Phase Operation (3-Wire USA)	2-12
2.8.2	342 to 457 VRMS 3-Phase Operation (4-Wire INTL).....	2-12
2.8.3	Single-Phase Input Connections.....	2-12
2.9	Output Connections to the Load.....	2-13
2.9.1	SW 5550AE Output Connections.....	2-13
2.9.2	SW 3700AE Output Connections.....	2-15
2.9.3	SW 1850AE Output Connections.....	2-15
2.9.4	Wiring of Unit	2-15
2.10	Wire Gauge Selection	2-15

SECTION 3 OPERATION

3.1	Introduction	3-1
3.2	Front Panel Controls	3-1
3.3	Menus	3-3
3.3.1	MAIN MENU	3-4
3.3.2	PROGRAM Menu	3-5
3.3.3	MEASURE Menu	3-8
3.3.4	WAVEFORM Menu.....	3-8
3.3.5	SEQUENCE Menu.....	3-14
3.3.6	INSTR (Instrument) Menu.....	3-21
3.3.7	SYSTEM Menu	3-22
3.4	Front Panel Programming Conventions	3-31
3.5	Front Panel Programming Exercise	3-32
3.6	SCPI Specification	3-36

SECTION 4 STANDARD WAVEFORMS

LIST OF TABLES

Table 2–1 Recommended Mounting Slide	2-3
Table 2–2 SW Input/Output Connectors	2-6
Table 2–3 EXT IN Connector Pinout.....	2-7
Table 2–4 DFI Connector Pinout.....	2-8
Table 2–5 IEEE 488.2 Connector Pinout	2-9
Table 2–6 Slave Connector Pinout	2-9
Table 2–7 Input Currents for 3-Phase Input Power	2-11
Table 2–8 Single-Phase Input Configurations.....	2-11
Table 2–9 Recommended Wire Gauge Selection Guide.....	2-16
Table 3–1 Sequence Execute Menu	3-20
Table 3–2 SELF-TEST Results Definitions	3-23
Table 3–3 System External Menu	3-26
Table 3–4 Fault Register Bit Definitions.....	3-27
Table 3–5 Fault Description and Action (FR1)	3-28
Table 3–6 Fault Description and Action (FR2)	3-29
Table 3–7 Fault Description and Action (FR3)	3-29

LIST OF FIGURES

Figure 1–1 Elgar Model SW 5550AE AC Power Source (Rack Mount Version)..... 1-1

Figure 2–1 Mounting Dimensions, SmartWave Front View2-3

Figure 2–2 Mounting Dimensions, SmartWave Top and Side Views.....2-4

Figure 2–3 SmartWave Rear Panel.....2-5

Figure 2–4 Parallel Connections.....2-14

Figure 2–5 Sense Lead Connections for 3-Phase Output2-14

Figure 3–1 Front Panel Controls (SW 5550AE).....3-1

SECTION 1

GENERAL DESCRIPTION

1.1 Introduction

The Elgar SmartWave™ Models SW 5550AE, SW 3700AE, and SW 1850AE use transformerless, direct coupled amplifiers with very low, uniform output impedance. Additionally, the controller allows for programmable output impedance and the injection of interharmonic signals. This technology allows you to provide full agency compliant AC mains power for testing to IEC 1000-3-2 and IEC 1000-3-3, and IEC 1000-4-13 (harmonic current emissions, voltage fluctuations/flicker, and harmonic/interharmonic voltage).

The SmartWave has a true arbitrary waveform generator based controller capable of creating complex waveforms with high DC content for simulating real world power irregularities, including phase controlled sub-cycle or multi-cycle dropouts, spikes, sags, surges, frequency excursions, plus frequency and voltage ramps (sweeps). The unit can also generate clipped waveforms, harmonic distortion, high current inrush, and other complex waveshapes.

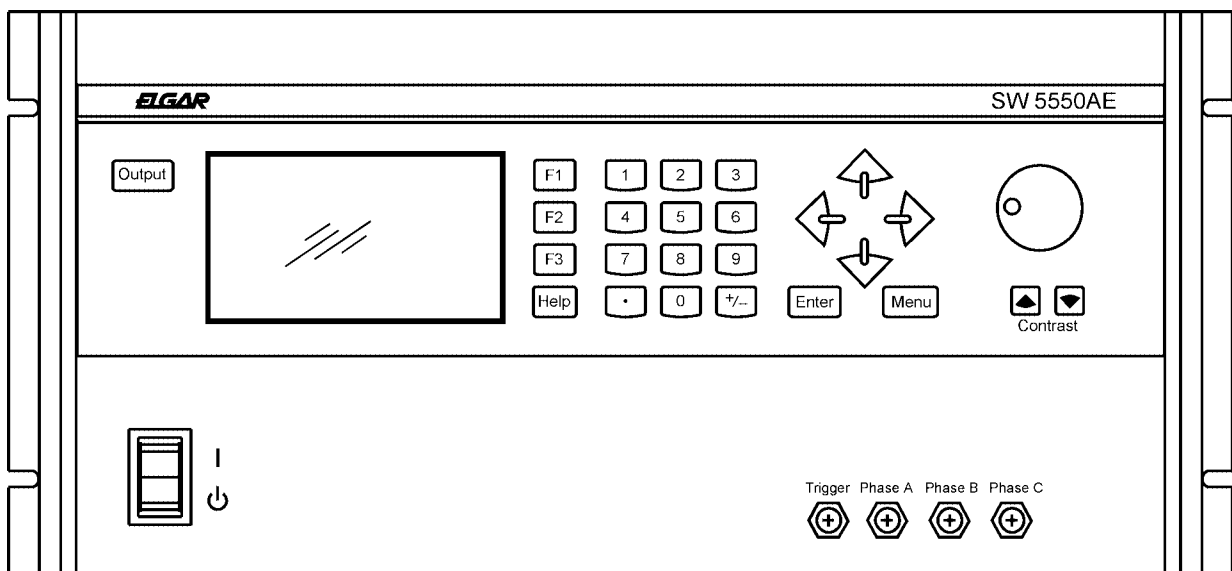

Figure 1–1 Elgar Model SW 5550AE AC Power Source (Rack Mount Version)

Programming is accomplished at the front panel or with a personal computer (PC) using optional software. A GPIB card in the computer is also required.

A library of 25 factory-supplied waveshapes is provided in Flash Memory. Non-volatile memory storage is available for an additional 50 user-created waveshapes.

Waveshapes from the libraries can be assigned amplitude and frequency parameters and be stored as setups in non-volatile memory for immediate user recall. In addition, you can create up to 1000 timed segments and link them together to form sequences (transient programs).

The backlit graphics LCD display allows quick confirmation of waveforms when created or edited from the front panel. Front panel BNCs provide waveform reference outputs for oscilloscope viewing. The front panel also includes a keypad, a rotary knob, and Help screens.

The SmartWave sources are true DC as well as AC power supplies. Up to 312 VRMS are available in AC or AC+DC modes. Multi-phase models can be switched to single or three-phased operation via the front panel or the GPIB.

A wide frequency range of DC or 40 Hz to 500 Hz is available for a broad array of applications. Utilizing the latest in AC switch mode technology, the SmartWave has less than -60 dB of noise and ripple with total harmonic distortion (THD) of <0.5% to 500 Hz. A crest factor of 4.0 provides high peak-to-RMS current capability. An optional power factor correction (PFC) of .99 is also available.

1.2 Input Specifications

Input Power Ranges: Factory configured 187 to 264 VRMS, 3 ϕ L-L (3 wire), or 342 to 457 VRMS, 3 ϕ L-L (4 wire). A chassis ground is also required for safety.

Input Power Factor: .6 with USA rectifier; .35 with INTL rectifier; .99 with input PFC option.

Input Frequency Range: 47 to 63 Hz

Efficiency: 70%, minimum, at full load.

Ride Through: 3 msec, minimum; 10 msec, minimum, with PFC option.

Input Current: Maximum currents are provided in Table 2–7 and Table 2–8.

Initial Turn-on Current Surge: Limited to less than peak value listed in Table 2–7 and Table 2–8.

1.3 Output Specifications: IEC Test Modes*

Calibration Interval: 1 year.

Power Factor of Load: 0 lagging to 0 leading.

AC or DC Output Voltage: 0 to 156 VRMS L-N range 1; 0 to 312 VRMS L-N range 2.

Output Current Per Phase: 16A to 115V in 156V range; 8A to 230V in 312V range (1850 VA maximum).

Crest Factor: 3.25 (peak output current to RMS output current).

Output Frequency: DC, or 40 to 500 Hz (sine); 40 to 63 Hz (complex waveforms); Interharmonics 16 to 3000 Hz (sine); Optional IWG*

Output Power: 1850 VA, maximum, per phase.

Total Harmonic Distortion (Full Linear Load or No Load): 0.25% maximum, 40 to 100 Hz; 0.5% maximum to 500 Hz. Typical: Less than 0.1% at 50 Hz.

AC Noise Level: >60 dB RMS below full output (sine wave, 40 to 500 Hz).

Amplitude Stability With Remote Sense: $\pm 0.1\%$ of full scale over 24 hours at constant line, load and temperature.

Load Regulation: $\pm 0.025\%$ of full scale voltage for a full resistive load to no load (RMS Servo Mode.)

Line Regulation (DC, or 40 to 500 Hz): $\pm 0.025\%$ of full scale for a $\pm 10\%$ input line change.

Voltage Accuracy (No Load, IEC Test Mode): $\pm 0.1\%$ of range. Add $\pm 0.1\%$ of full scale for "AC PLUS DC" mode. Valid for 5 to 156 VRMS and 10 to 312 VRMS at 25°C (77°F), sense leads connected. Temperature coefficient less than 50 ppm/°C.

Voltage Resolution: 0.05% of full scale.

Frequency Resolution: 0.01 Hz: 40 to 99.99 Hz
0.05 Hz: 100 to 500 Hz

Frequency Accuracy: $\pm 0.01\%$ at 25°C $\pm 0.001\%/^{\circ}\text{C}$.

* See *Glossary of Technical Terms* at the end of this section.

Phase Accuracy, Phase-to-Phase Balanced Linear Resistive Load:

±1°, 40 to 500 Hz.

Phase Angle Resolution: 0.1°.

Remote Output Voltage Sense: 5 VRMS total lead drop, maximum.

Output Impedance:**1850, 1 Phase, 312V Range:**

Low Impedance Mode: Less than $0.07+j0.05 \Omega$ (at 50 Hz)

Reference Impedance Mode: $(0.40+j0.25) \Omega \pm 3.0\%$ (at 50 Hz)

3700, 1 Phase, 312V Range:

Low Impedance Mode: Less than $0.05+j0.04 \Omega$ (at 50 Hz)

Reference Impedance Mode: $(0.40+j0.25) \Omega \pm 3.0\%$ (at 50 Hz)

5550, 1 Phase, 312V Range:

Low Impedance Mode: Less than $0.03+j0.03 \Omega$ (at 50 Hz)

Reference Impedance Mode: $(0.40+j0.25) \Omega \pm 3.0\%$ (at 50 Hz)

Low Impedance Mode meets or exceeds the requirements of IEC-1000-3-2, Annex A, Supply Source. Valid for equipment classes A, B, C, D, and fluctuating harmonics.

Reference Impedance Mode conforms to the requirements of IEC 725.

1.4 Waveform Specifications

Waveshape Libraries: 25 factory-supplied in flash memory; storage available for up to 50 user created in non-volatile RAM.

User-Created Setups: A total of 100 steady-state waveforms, consisting of parameters such as waveshapes from the libraries plus amplitude, frequency, phase angle and current limit.

Sequencing/Transient Programs: 1000 user-created segments stored in non-volatile RAM up to 100 segments per sequence. Segments include wave-shape, amplitude, frequency, phase angle, **time** (from 1 msec to 7 days), and number of cycles.

MIL-STD-704 Transients: Factory-supplied sequencing program.

1.5 Interharmonics Waveform Generator (Optional)

Interharmonic output will be combined with Phase A, B, and C outputs. Phase Outputs will be referred to as the Fundamental Output. The specifications below apply only to Output Range 2, 312 VRMS:

Reference: IEC 1000-4-13
Low Frequency Phenomena

Frequency Range: 15 Hz to 3000 Hz

Frequency Accuracy: 0.5% of interharmonic output

Frequency Resolution: 0.05% of interharmonic programmed value

Amplitude Range: 0 to 40.0 VRMS

Amplitude Accuracy: 0.23 VRMS

Amplitude Resolution: 0.02 VRMS

1.6 Protection and Safety

Overvoltage Shutdown: Programmable for 15V to 255V peak, 156V range; 30V to 510V peak, 312V range.

Undervoltage Shutdown: Automatic, not programmable.

Programmable Current Limit Shutdown: Can be set to 1% of range; 0.5A to 16A for 156V range, 0.5A to 8A for 312V range.

Programmable Current Limit with Timed Shutdown: Can be set to 1% of range; the timeout can be set from 100 msec to 10 sec.

Programmable Constant Current: Can be set to 1% of range; 0.5A to 16A for 156V range, 0.5A to 8A for 312V range.
For all current accuracies, $\pm 1\%$ of full scale, add $\pm 1.5\%/kHz$ above 500 Hz.
For paralleled amplifiers, add $\pm 1\%$.

Temperature Coefficient: <200 ppm/ $^{\circ}C$.

Overtemperature Shutdown: Automatic, not programmable.

1.7 Agency Requirements

The SmartWave is designed to meet the following agency requirements:

- UL 3111
- CUL 1010
- EN 61010
- EN 50081-2
- EN 50082-1
- IEC 1000-3-2, Annex A, Supply Source
- IEC 725 Reference Impedance
- IEC 801-2, -3 and -4
- IEC 1000-4-13, Interharmonics Waveform Generator
- FCC Part 15, Class A

1.8 Physical Specifications (All Models)

Height: 8.75" (222 mm)

Width: 19" (483 mm)

Depth: 23.5" (597 mm)

Weight: SW 5550AE: 126.5 lbs. (57.2 kg)
SW 3700AE: 100.5 lbs. (45.6 kg)
SW 1850AE: 73 lbs. (33.1 kg)

Cooling: Air is drawn in from the top and sides, and exhausted through the rear of the chassis. 200 CFM is required for specified operation.

1.9 Environmental Data

Operating Temperature: 0°C to 45°C (32°F to 113°F).

Note temperature measured at air inlet of SW. If cabinet mounted, cabinet inlet air may be rated at lower maximum temperature due to warming of inlet air.

Storage Temperature: -40°C to 70°C (-40°F to 158°F).

Humidity (Non-condensing): 0 to 80% at 31°C (88°F);
derate to 50% at 40°C (104°F).

Altitude: Operating: 10,000 ft. (3,048 m); non-operating: 40,000 ft. (12,192 m).

1.10 Other Standard Features

- **1- to 3-Phase Programmable**
- **IEEE 488.2 Interface**
- **SCPI Protocol**
- **Waveform Trigger Output**
(1 Meg Ω Load Drive; positive edge is at $0^\circ \pm 30\mu\text{s}$, 0 to 5V logic)
- **BNC Outputs for Waveform Viewing**
(1 Meg Ω Load Drive, 1.25 VRMS = Full Scale)
- **SYNC OUT.** User programmed for:
Cycle Start, all cycles
Segment Start, all segments
Segment Start, selected segments
For loads $\geq 2\text{ k}\Omega$: $V_{\text{out}} \leq 1\text{V}$ Low State; $V_{\text{out}} \geq 2.4\text{V}$ High State; Negative edge is at $0^\circ \pm 30\ \mu\text{s}$.
- **CLOCK/LOCK**
CLOCK pulses at programmed frequency for loads $\geq 2\text{ k}\Omega$. $V_{\text{out}} \leq 1\text{V}$ Low State; $V_{\text{out}} \geq 2.4\text{V}$ High State. Negative edge is at $0^\circ \pm 30\mu\text{s}$.
LOCK locks output to input 'TTL' frequency; signal needs to supply pull down current of 15 mA with voltage drop of $\leq 0.6\text{V}$; no pull up needed. Negative edge is at $0^\circ \pm 30\ \mu\text{s}$.
- **PLL Specifications**
External PLL input frequency range is 45.00 Hz to 500.00 Hz.
Tracking range is $\pm 10\%$ of programmed PLL center frequency.
External PLL input duty cycle is $50\% \pm 10\%$.
External PLL input slew rate is .02% of input frequency/second, maximum, which produces a maximum phase shift of 5° from the external PLL input falling edge to the output rising edge.
The rising edge of the output will be locked to the falling edge of the external PLL input and will have less than a 30 μsec propagation delay.
Maximum output jitter when locked is $< 1\%$ of external PLL input period.
PLL lock is achieved in < 5 seconds.

- **External Amplitude Modulation**
0 to 5 VRMS provides 0 to $\geq 20\%$ output amplitude modulation ($\pm 2\%$ of full scale output).
- **External Direct Input**
Normal Amplifier, 0 to 5 VRMS (DC to 500 Hz) or ± 5 VDC input for zero to full scale programmed voltage output ($\pm 2\%$ of full scale output).
- **External Gain Control**
0 to ± 7.07 VDC provides zero to full scale programmed voltage output ($\pm 2\%$ of full scale output).
- **External Input Impedance**
 ≥ 30 k Ω .
- **System Firmware**
System firmware is stored in flash memory. This makes it possible to upgrade the firmware without disassembling or returning the unit.

1.11 Options

- Paralleable For Additional Power above 5550A VA
- External Waveform Creation Software
- Input Power Factor Correction to 0.99
- Interharmonics Waveform Generator
- 5V and 26V, 26VA Auxiliary AC outputs for 115V input, 350-450 Hz.

1.12 Glossary of Technical Terms

1.12.1 IEC Test Modes

The SWAE product line is designed as a supply source for IEC testing. The power ON defaults to the low impedance mode, 50 Hz, 312V range. On the System External menu, this corresponds to the LOW FREQ menu item set to ON. To select the reference impedance mode, set both LOW FREQ and FLICKER to ON.

Output impedance (and load regulation) are defined by the particular mode selected. Refer to Section 1.3, Output Impedance, for more information.

The SWAE output voltage is calibrated at no load. Under load, the output voltage is modified by (I_{LOAD}) (Z_{OUT}).

Low impedance mode is used for IEC 1000-3-2 current harmonics testing, as well as general testing. Reference impedance mode is used for IEC 1000-3-3 voltage fluctuations and flicker testing.

1.12.2 Interharmonic Waveform Generator (IWG)

The IWG is used for IEC 1000-4-13, interharmonic voltage immunity testing. A user-specified amplitude and frequency is summed to the main output.

SPECIFICATIONS ARE SUBJECT TO CHANGE WITHOUT NOTICE.

This page intentionally left blank.

SECTION 2 INSTALLATION

2.1 Introduction

The Elgar Model SW 5550AE, SW 3700AE, or SW 1850AE has been fully calibrated and tested prior to shipment. The instrument is ready for immediate use upon receipt.



WARNING! The SmartWave unit weighs 73–126.5 lbs. (33.1–57.2 kg), depending on the model. A minimum two–person lift is required!



WARNING! Hazardous voltages are present when operating this equipment. Please read the Safety Notice at the beginning of this manual prior to installation, operation, or maintenance.

2.2 Unpacking

Perform a visual inspection of the shipping container prior to accepting the package from the carrier. If extensive damage to the shipping container is evident, a description of the damage should be noted on the carrier's receipt and signed by the driver of the carrier agent.

If damage is not apparent until the instrument is unpacked, a claim for concealed damage should be placed with the carrier. In addition, the shipping container(s) and filler material should be saved for inspection. Forward a report of damage to the Elgar Service Department. Elgar will provide instructions for repair or replacement of the instrument.

If the instrument needs to be returned to Elgar, suitable shipping containers and packing materials must be used. If proper packing material is not available, contact Elgar to provide containers and shipping instructions.

2.3 Pre-Installation Inspection

Perform a visual inspection of the instrument when it is removed from the shipping container. Check for shipping damage such as dents, scratches, distortion, and damaged connectors.

2.4 Installation

The SmartWave unit is 8.75" (222 mm) high and is designed to be installed in a standard 19" (483 mm) RETMA rack or a transit case; pem-nuts are provided for mounting optional slides.



CAUTION!

Avoid blocking the instrument air intakes or exhaust.

2.5 Air Intake and Exhaust

The air intakes are located on the top and side panels of the instrument and the exhaust is through the rear panel. Care must be taken not to block the side air intakes; the top air intakes allow for improved cooling if this air is available. No special vertical separation is required when stacking instruments. However, a 1.75" (45 mm) vertical spacer above the instrument may improve cooling. The temperature of the intake air should not exceed 113°F (45°C).

At full power the unit dissipates over 2250W with the PFC option. It is important that the heat produced is properly vented to the exterior of the chassis. Special baffling to control air flow may be required to prevent hot exhaust air being drawn into the intakes if the unit is to be run continuously at full power.

The preferred mounting method for full power operation is bottom mounting. Slide mounting may impair air flow from the side air intakes. If slides must be used, select narrow slides to minimize restrictions to airflow and select cabinets without wide rails that can block airflow. Refer to Table 2–1 for the recommended slides and Figure 2–2 for the mounting location.

NOTE: Periodic cleaning is required to ensure that dust build-up within the chassis does not restrict airflow through the modules, which could lead to overheating of the system. A strong vacuum cleaner may be used to remove dust from the various assemblies within the SW chassis. Compressed air is not recommended.

TYPE	MANUFACTURER	PART NUMBER
Mounting Kit (for slides)	Jonathan	BK-3
Slides	Accuride	C-3307-16D

Table 2–1 Recommended Mounting Slide

2.6 Installation/Dimensional Drawing

Refer to Figure 2–1 and Figure 2–2 for information on outline and mounting dimensions of the unit and customer wiring conduit details. Refer to Figure 2–3 and Table 2–2 through Table 2–6 for rear panel connector information.

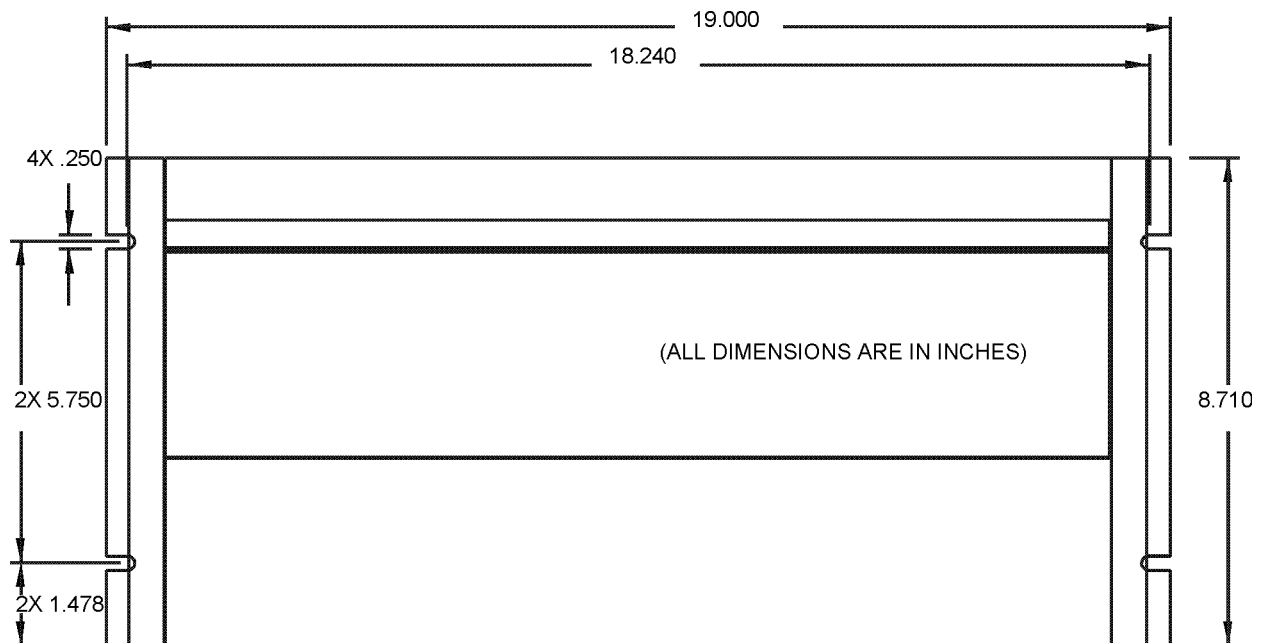

Figure 2–1 Mounting Dimensions, SmartWave Front View

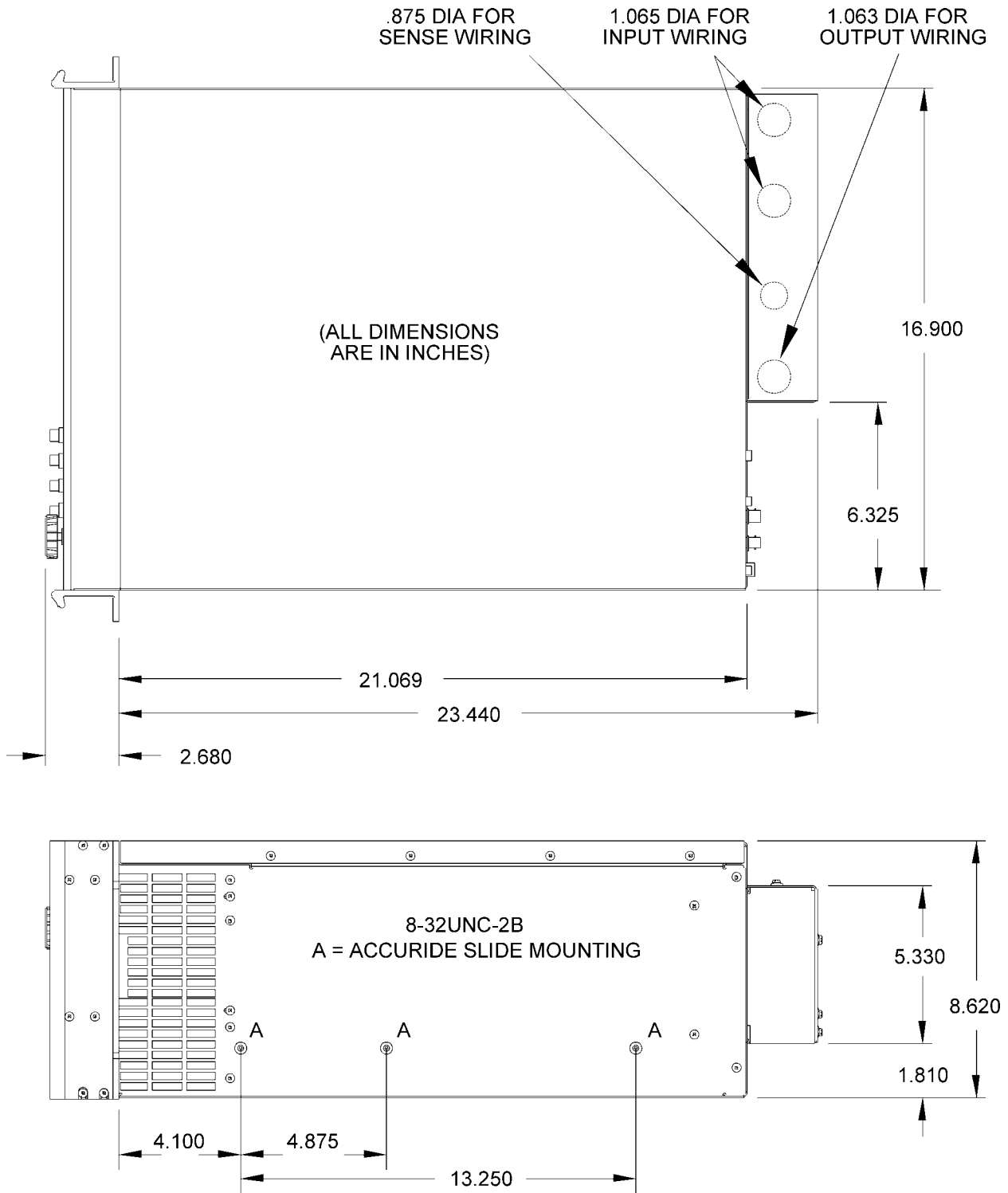

Figure 2-2 Mounting Dimensions, SmartWave Top and Side Views

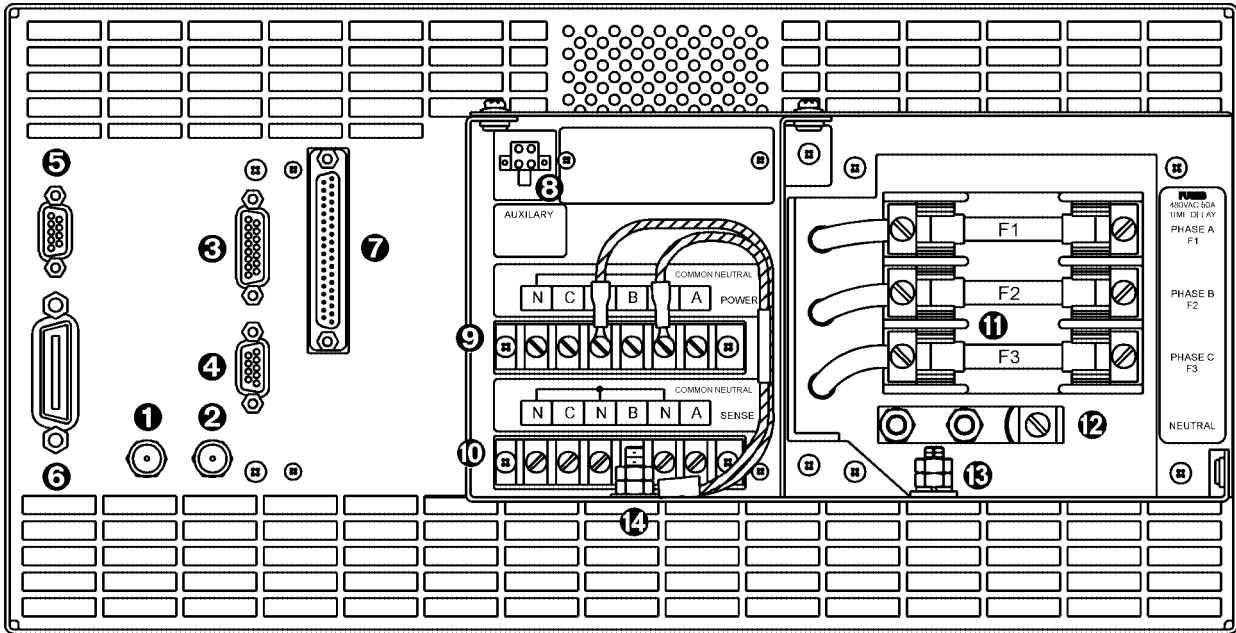

Figure 2-3 SmartWave Rear Panel

2.7 Input/Output Connectors

Table 2–2 provides a listing of the SW input and output connectors and other data. Table 2–3 through Table 2–6 provide specific pinout information.

NOTE: The RS232 AND AUX OUT connectors (Figure 2–3, Items 4 and 8, respectively) are Elgar proprietary; thus, the pinouts will not be provided.

ITEM #	NAME	TYPE	MANUFACTURER / PART #
1	SYNC OUT	BNC	KINGS, PN KC-79-179
2	CLOCK & LOCK	BNC	KINGS, PN KC-79-179
3	EXT IN $\pm 7.5V$ MAX	15 POS SUB-D FEMALE (Gold Contacts)	AMP, PN 747052-3
4	RS232	9 POS SUB-D MALE (Gold Contacts)	AMP, PN 747043-4
5	DFI	9 POS SUB-D FEMALE (Gold Contacts)	AMP, PN 747052-4
6	IEEE 488.2	25 POS FEMALE (Gold Contacts)	AMP, PN 554434-1
7	SLAVE	37 POS SUB-D FEMALE	ITT CANNON, PN ADC37SOL2
8	AUX OUT	4 POS MINIFIT JR	MOLEX, PN 39-29-9045
9	OUTPUT POWER TERMINAL BARRIER	6 POS (#6 HDW)	MAGNUM, PN A304106-07-CA-MP8
10	REMOTE SENSE TERMINAL BARRIER	6 POS (#6 HDW)	MAGNUM, PN A304106-07-CA-MP8
11	PHASE A FUSE F1*	480VAC 50A TIME DELAY	BUSSMAN, SC50 LITTELFUSE, SLC50
	PHASE B FUSE F2*	480VAC 50A TIME DELAY	BUSSMAN, SC40 LITTELFUSE, SLC40
	PHASE C FUSE F3*	600VAC 20A TIME DELAY	GOULD SHAWMUT ATDR20 LITTELFUSE CCMR20
12	INPUT, NEUTRAL LUG, SINGLE BARREL	90A, 8AWG-2AWG	PANDUIT, PN C070-14-Q
13	SAFETY GROUND	STUD	#1/4-20 X .75 LG
14	CHASSIS GROUND	STUD	#1/4-20 X .75 LG

* Refer to Table 2–7 and Table 2–8 for Fuse Ampere Rating

Table 2–2 SW Input/Output Connectors (see Figure 2–3)

2.7.1 BNC Connectors

The diagram below illustrates the signal and return connections. Refer to Figure 2–3, Items 1 and 2.

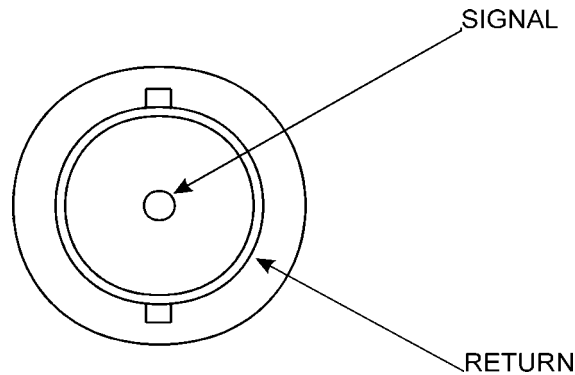

2.7.2 EXT IN (External Input)

Refer to Figure 2–3, Item 3.

PIN #	MNEMONIC	LEVEL
1	SHIELD	CHASSIS
2	SHIELD	CHASSIS
3	SHIELD	CHASSIS
4	SHIELD	CHASSIS
5	SHIELD	CHASSIS
6 through 9	Not Used	Not Used
10	EXT_IN_A	± 7.25 V _{peak} DC to 500 Hz, ≥ 30 k Ω
11	EXT_IN_B	± 7.25 V _{peak} DC to 500 Hz, ≥ 30 k Ω
12	EXT_IN_C	± 7.25 V _{peak} DC to 500 Hz, ≥ 30 k Ω
13	EXT_RETURN	± 20 V _{peak} WRT CHASSIS GROUND
14 and 15	Not Used	Not Used

Table 2–3 EXT IN Connector Pinout

2.7.3 DFI (Direct Fault Indicator)

The DFI connector on the rear panel has both input and output functionality.

The DFI Output Relay indicates a shutdown fault has occurred on the SW. It is a SPST reed relay with rear panel connections to the normally closed output contacts. When the SW is operating the relay is energized so that the contacts are open. When a fault occurs, or if the unit should lose power, the relay closes to indicate a fault has occurred. The DFI Output Relay will remain latched until the front panel Power switch is cycled.

The DFI Input Signal is used to command the SW to open the Output relay, and close the DFI relay. It is a TTL-compatible input with a 1 k Ω input impedance, a 10 k Ω pullup to +5 VDC, and clamping diodes to +5 VDC and ground. A signal with a negative going edge from +5 VDC to ground will trigger the DFI response.

Refer to Figure 2–3, Item 5.

PIN #	MNEMONIC	LEVEL
1	DFI RLY COMM	—
2	Not Used	—
3	DFI IN +	TTL (10 k Ω input impedance)
4 and 5	Not Used	—
6	DFI RLY N.O.	—
7	Not Used	—
8	DFI IN RTN	TTL
9	IEEE 488.2	SIGNAL GND

Table 2–4 DFI Connector Pinout

2.7.4 IEEE 488.2

Refer to Figure 2–3, Item 6.

PIN #	MNEMONIC	PIN #	MNEMONIC	PIN #	MNEMONIC
1	DIO1	9	IFC	17	REN
2	DIO2	10	SRQ	18	GND (TW PAIR W/DAV)
3	DIO3	11	ATN	19	GND (TW PAIR W/NRFD)
4	DIO4	12	SHIELD	20	GND (TW PAIR W/NDAC)
5	EOI	13	DIO5	21	GND (TW PAIR W/IFC)
6	DAV	14	DIO6	22	GND (TW PAIR W/SRQ)
7	NRFD	15	DIO7	23	GND (TW PAIR W/ATN)
8	NDAC	16	DIO8	24	SIGNAL GROUND

Table 2–5 IEEE 488.2 Connector Pinout

2.7.5 Slave Connector

Refer to Figure 2–3, Item 7.

PIN #	MNEMONIC	PIN #	MNEMONIC	PIN #	MNEMONIC
1	AGND_BUS	14	AGND_BUS	26	-15A_BUS
2	AGND_BUS	15	ISNSC-_BUS	27	AGND_BUS
3	AGND_BUS	16	ISNSB-_BUS	28	+5D_MAS
4	+15A_BUS	17	AGND_BUS	29	AGND_BUS
5	AGND_BUS	18	ISNSA-_BUS	30	DRC+_BUS
6	-15A_BUS	19	NOT USED	31	DRB+_BUS
7	/R1_BUS	20	TSA_BUS	32	AGND_BUS
8	/R0_BUS	21	TSB_BUS	33	DRA+_BUS
9	+5D_MAS	22	TSC_BUS	34	ISNSC+_BUS
10	DRC-_BUS	23	/RST_BUS	35	AGND_BUS
11	AGND_BUS	24	/FAULT_BUS	36	ISNSB+_BUS
12	DRB-_BUS	25	/DC_STOP_BUS	37	ISNSA+_BUS
13	DRA-_BUS				

Table 2–6 Slave Connector Pinout

Electrical Specification: All voltages less than $\pm 20\text{V}_{\text{PK}}$ with respect to chassis ground.

2.7.6 Grounding



The three waveform outputs (TRIGGER OUT, CLOCK & LOCK, SYNC OUT) share the same ground. This ground should not exceed $\pm 20V$ Peak from chassis ground. If possible, this ground should be connected to the chassis.

DFI and IEEE 488.2 share the same signal ground.

2.8 Input Power Requirements

Input power is connected to the SW 5550AE, SW 3700AE, or SW 1850AE via the rear panel connectors. See Table 2–7 and Table 2–8 for input current values.



WARNING!

An overcurrent protection device (i.e., circuit breaker) is required in the building installation. The circuit breaker should be rated for continuous current as required by the SW system (see Table 2–2). Installation should comply with local safety standards.

A device to disconnect the SW system from the energy supply source is also required. This switch or circuit breaker must be close to the SW system, within easy reach of the operator, and clearly labeled as the disconnection device for the SW system.

		MAXIMUM LINE CURRENT	MAXIMUM NEUTRAL CURRENT	F1-F3 FUSE RATING	RECOMMENDED CIRCUIT BREAKER RATING (MAX.)
SW 5550AE					
PFC	USA	27A RMS	Not Required	40A	40A RMS
PFC	INTL	14A RMS	14A RMS	20A	20A RMS
RECT	USA	42A RMS	Not Required	50A	50A RMS
RECT	INTL	42A RMS	72A RMS	50A	50A RMS
SW 3700AE					
PFC	USA	27A RMS	Not Required	40A	40A RMS
PFC	INTL	14A RMS	14A RMS	20A	20A RMS
RECT	USA	28A RMS	Not Required	40A	40A RMS
RECT	INTL	28A RMS	48A RMS	40A	40A RMS
SW 1850AE					
PFC	USA	15A RMS	Not Required	20A	20A RMS
PFC	INTL	14A RMS	14A RMS	20A	20A RMS
RECT	USA	14A RMS	Not Required	20A	20A RMS
RECT	INTL	14A RMS	25A RMS	20A	20A RMS

Table 2-7 Input Currents for 3-Phase Input Power

		REQ'D INPUT TERMINAL JUMPER CONNECTIONS	CONNECT 1-PHASE INPUT POWER TO	VOLTAGE	MAXIMUM INPUT CURRENT	F1-F3 FUSE RATING	RECOMMENDED CIRCUIT BREAKER RATING (MAX.)
SW 5550AE							
PFC*	USA	F1 to F2	F1, F3	187-264 VRMS, L-L	30A RMS	40A	40A RMS
PFC	INTL	F1 to F2, F2 to F3	F1, Neutral	187-264 VRMS, L-N	45A RMS	20A	40A RMS
SW 3700AE							
PFC	USA	F1 to F2	F1, F3	187-264 VRMS L-L	30A RMS	40A	40A RMS
PFC	INTL	F1 to F2, F2 to F3	F1, Neutral	187-264 VRMS L-N	30A RMS	20A	40A RMS
SW 1850AE							
PFC	USA	None	F1, F3	187-264 VRMS L-L	15A RMS	20A	20A RMS
PFC	INTL	None	F1, Neutral	187-264 VRMS L-N	15A RMS	20A	20A RMS

* Only Phase A and Phase B are present at the output

Table 2-8 Single-Phase Input Configurations

2.8.1 187 to 264 VRMS 3-Phase Operation (3-Wire USA)

Connect the input wires to the phase A (F1), B (F2), and C (F3) input fuse terminals (no Neutral is required). **Ensure that the chassis safety ground is also connected.** Use cables with ratings equal to or greater than the current rating listed on the unit or in Table 2–7. Any phase sequence of wiring can be used.

2.8.2 342 to 457 VRMS 3-Phase Operation (4-Wire INTL)

It is essential that the Neutral connection is present when using the unit. An external circuit breaker is required for the 3-phase voltages. Only those units factory set at this voltage will operate at this voltage.



CAUTION!

For units built before June 2004, the Neutral must not be broken by an external switch. Severe damage to the unit may occur if Neutral is broken and phase voltage is present.

Connect the input wires to phases A (F1), B (F2), C (F3) and Neutral. **Ensure that the chassis safety ground is also connected.** Use cables with ratings equal to or greater than the current rating listed on the unit or in Table 2–7.

2.8.3 Single-Phase Input Connections

The SW system is designed for three-phase input power operation, either 3-wire (USA) or 4-wire (EUR) plus a chassis safety ground. However, if only single-phase input power is available, the configurations listed in Table 2–8 are possible.

An overcurrent protection device and a device for disconnecting the single-phase energy supply source are required as indicated in Section 2.8 above.

2.9 Output Connections to the Load

2.9.1 SW 5550AE Output Connections

The Model SW 5550AE can power 1-phase, 2-phase and 3-phase loads. Local or remote sensing can be used; if no sense lines are connected, the unit automatically reverts to local sense. Outputs may be directly paralleled for greater power. If the outputs are paralleled it is important to program the unit to the parallel mode before shorting the outputs together (refer to Figure 2–4). Outputs cannot be placed in series since the Neutral is common. However, by programming two phases 180° apart, double voltage, single phase is achieved.

Any phase sequence of wiring can be used.

The sense Neutral is also common. Thus, it is important to wire the sense wires properly (refer to Figure 2–5). If remote sense is used:

- Sense A is connected to Power A;
- Sense B is connected to Power B;
- Sense C is connected to Power C; and
- Neutral Sense is connected to Neutral Power.



Output power neutral must be connected to chassis ground for safe operation. The SW system is shipped with a green/yellow wire connected from output power neutral to chassis ground. It is important that the Neutral not be >20V away from the chassis potential; the unit will shut down if this voltage is exceeded.

If a transformer or inductive load is present, the unit should be programmed to AC. This prevents small amounts of DC being generated, which may saturate the magnetics.

For best performance, the sense leads should be connected and output neutral should be connected to chassis ground.

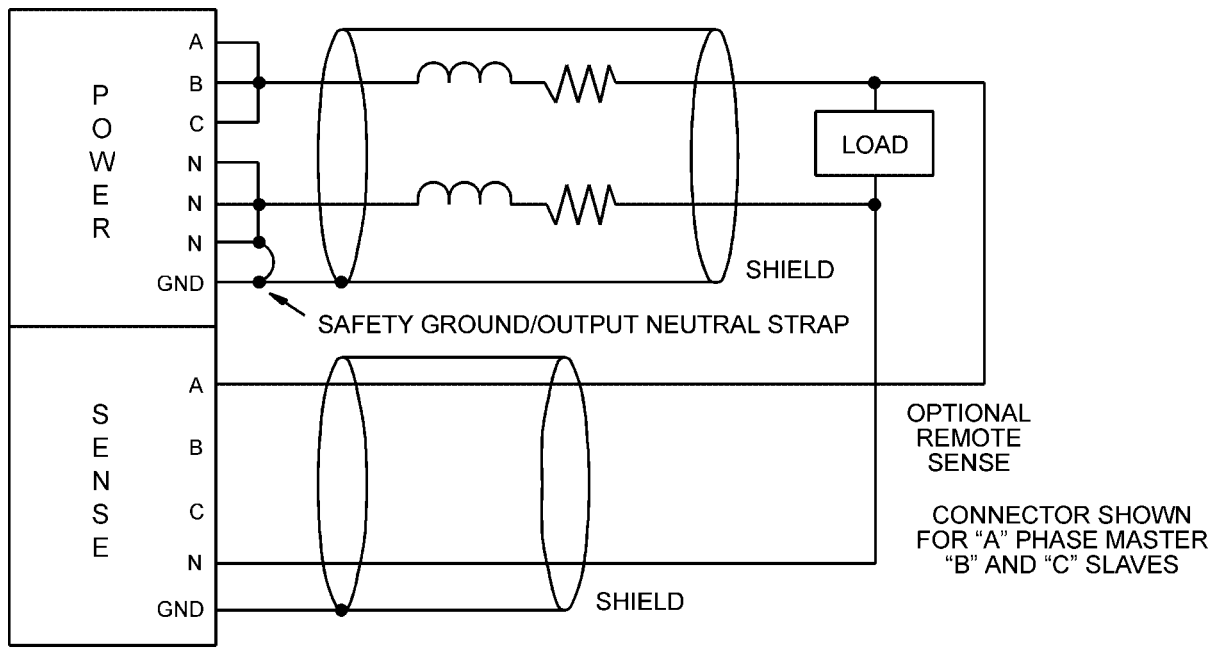

SW 5550AE

Figure 2-4 Parallel Connections

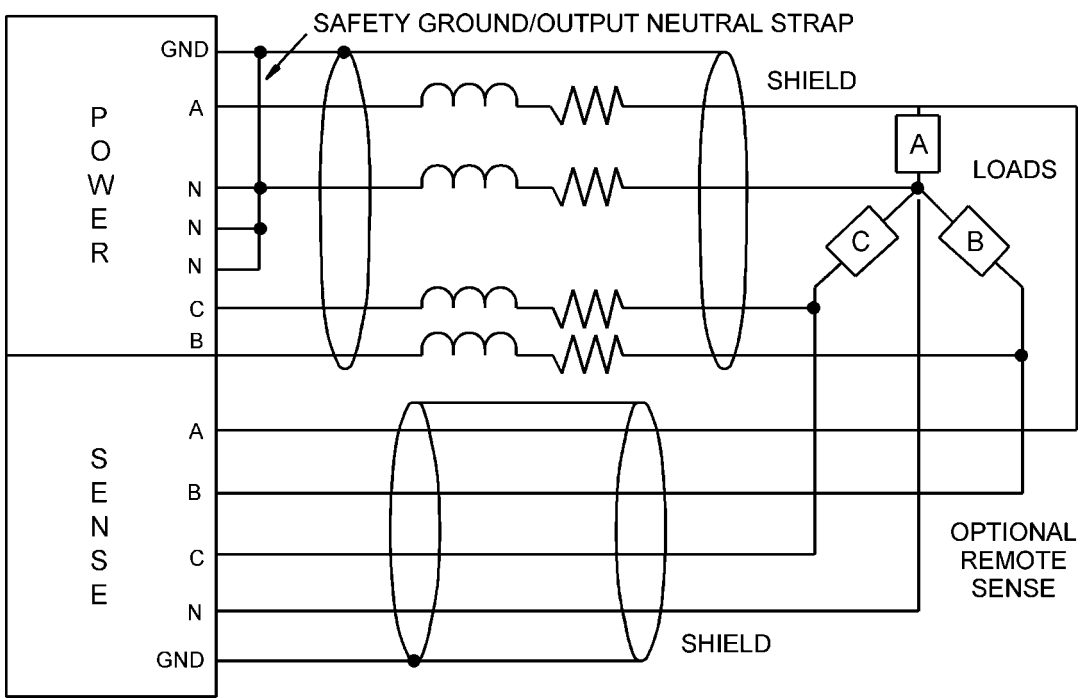

SW 5550AE

Figure 2-5 Sense Lead Connections for 3-Phase Output

The output power and sense leads should be shielded and the shield connected to the chassis to prevent noise pickup (or radiation to sensitive circuits in the vicinity). Again, the shield should be connected to chassis ground.

Due to the high voltages present, 312 VRMS line-to-neutral and 437 VRMS line-to-line cables rated to these voltages must be used for both the Power and Sense leads.

2.9.2 SW 3700AE Output Connections

The Model SW 3700AE has phases A and B present; phase C is open circuit.

2.9.3 SW 1850AE Output Connections

The Model SW 1850AE has only phase A present; phases B and C are open circuits.

2.9.4 Wiring of Unit

Due to the high voltages and frequencies involved, it is recommended that all input and output wiring is protected with flexible conduit. Holes for this purpose are made in the terminal box (see Figure 2–2). All wiring must meet local standards for safety.

2.10 Wire Gauge Selection

The following guidelines assist in determining the optimum cable specification for your power applications. These guidelines are equally applicable to both DC and low frequency AC (up to 450 Hz) power cabling. The same engineering rules apply whether going into or out of an electrical device. Thus, this guide applies equally to the input cable and output cable for this Elgar instrument and application loads.

Power cables must be able to safely carry maximum load current without overheating or causing insulation destruction. It is important to everyday performance to minimize IR (voltage drop) loss within the cable. These losses have a direct effect on the quality of power delivered to and from instruments and corresponding loads.

When specifying wire gauge, the operating temperature needs to be considered. Wire gauge current capability and insulation performance drops with the increased temperature developed within a cable bundle and with increased environmental temperature. Thus, short cables with generously derated gauge and insulation properties are recommended for power source applications.

Avoid using published commercial utility wiring codes. These codes are designed for the internal wiring of homes and buildings and accommodate the safety factors of wiring loss, heat, breakdown insulation, aging, etc. However, these codes consider that up to 5% voltage drop is acceptable.

Such a loss directly detracts from the quality performance specifications of this Elgar instrument. Frequently, these codes do not consider bundles of wire within a cable arrangement.

In high performance applications, as in motor start-up and associated inrush/ transient currents, additional consideration is required. The cable wire gauge must consider peak voltages and currents which may be up to ten times the average values. An underrated wire gauge adds losses which alter the inrush characteristics of the application and thus the expected performance.

Table 2–9 identifies popular ratings for DC and AC power source cable wire gauges.

<u>COLUMN 1:</u> SIZE (AWG)	<u>COLUMN 2:</u> AMPERES (MAXIMUM)	<u>COLUMN 3:</u> OHMS/100 FEET (ONE WAY)	<u>COLUMN 4:</u> IR DROP/100 FEET (COL. 2 X COL. 3)
14	15	0.257	3.85
12	20	0.162	3.24
10	30	0.102	3.06
8	40	0.064	2.56
6	55	0.043	2.36
4	70	0.025	1.75
2	95	0.015	1.42
1/0	125	0.010	1.25
3/0	165	0.006	1.04

Table 2–9 Recommended Wire Gauge Selection Guide

The following notes apply to Table 2–9 and to the power cable definition:

1. The above figures are based upon insulated copper conductors at 25°C (77°F), two current carrying conductors in the cable plus a safety (chassis) ground.

Columns 3 and 4 refer to “one way” ohms and IR drop of current carrying conductors (e.g., a 50-foot cable contains 100 feet of current carrying conductor).

2. Determine which wire gauge for the application by knowing the expected peak load current (I_{peak}), the maximum tolerated voltage loss (V_{loss}) within the cable, and the one way cable length.

The formula below determines which ohms/100 feet entry is required from Column 3. Read the corresponding wire gauge from Column 1.

(Column 3 value) =

$$V_{\text{loss}}/[I_{\text{peak}} \times 0.02 \times (\text{cable length})]$$

Where:

Column 3 value =

Entry of the table above.

Cable length =

One way cable length in feet.

V_{loss} =

Maximum loss, in volts, permitted within cable.

Special case: Should the V_{loss} requirement be very loose, I_{peak} may exceed the maximum amperes (Column 2). In this case, the correct wire gauge is selected directly from the first two columns of the table.

Example: A 20 ampere (I_{peak}) circuit which may have a maximum 0.5 volt drop (V_{loss}) along its 15-foot cable (one way cable length) requires (by formula) a Column 3 resistance value of 0.083. This corresponds to wire gauge size 8 AWG.

If the cable length was 10 feet, the Column 3 value would be 0.125 and the corresponding wire gauge would be 10 AWG.

3. Aluminum wire is not recommended due to soft metal migration at the terminals, which may cause long term (on the order of years) poor connections and oxidation. If used, increase the wire gauge by two sizes (e.g., specify 10 gauge aluminum instead of 14 gauge aluminum).
4. Derate the above wire gauge (use a heavier gauge) for higher environmental temperatures since conductor resistance increases with temperature.

<u>Temperature</u>	<u>Current Capability</u>
40°C, 104°F	80%

5. Derate the above wire gauge (use a heavier gauge) for an increased number of current carrying conductors. This offsets the thermal rise of bundled conductors.

<u>Number of Conductors</u>	<u>Current Capability</u>
3 to 6	80%
Above 6	70%

6. The preferred insulation material is application dependent. Elgar's recommendation is any flame retardant, heat resistant, moisture resistant thermoplastic insulation rated to a nominal 75°C (167°F). Voltage breakdown must exceed the combined effects of:
 - The rated output voltage;
 - Transient voltages induced onto the conductors from any source;
 - The differential voltage to other nearby conductors; and,
 - Safety margins to accommodate degradations due to age, mechanical abrasion, and insulation migration caused by bending and temperature.
7. As frequency increases, the magnetic field of the current carrying conductors becomes more significant in terms of adverse coupling to adjacent electrical circuits. Use twisted pairs to help cancel these effects. Shielded twisted pairs are even better. Avoid close coupling with nearby cables by using separate cable runs for high power and low power cables.
8. The above general values and recommendations should be reviewed, modified and amended as necessary, for each application. Cables should be marked with appropriate safety WARNING decals as hazardous voltages may be present.

SECTION 3 OPERATION

3.1 Introduction

The following is an overview of the controls and display for the SmartWave unit. Context-sensitive help is available from the front panel by pressing the **Help** key.

3.2 Front Panel Controls

The SW front panel is used for programming and data entry in local mode operation. The front panel is shown in Figure 3–1, followed by a description of each of the controls.

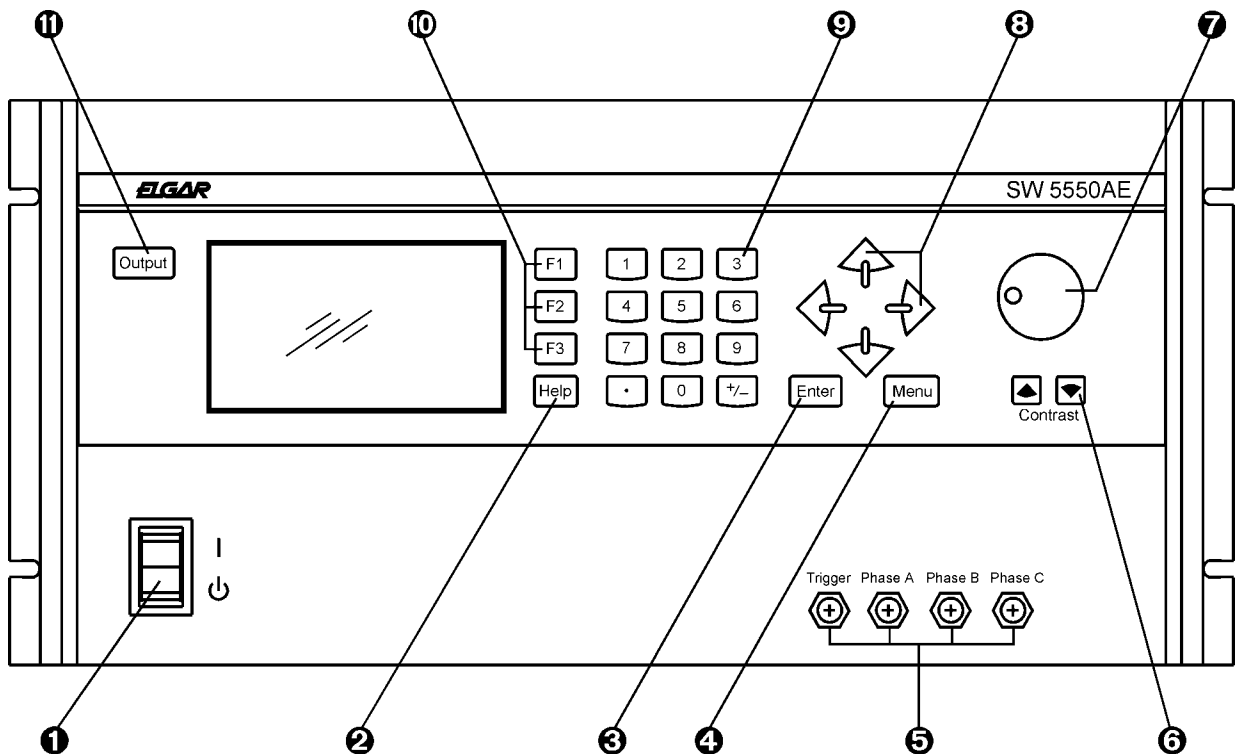

Figure 3–1 Front Panel Controls (SW 5550AE)

- ➊ **POWER ON/STANDBY SWITCH.** Pressing the top portion of the switch turns power on; pressing the bottom portion of the switch places the unit in the STANDBY mode.

When power is turned on, the unit goes through the power up cycle. This cycle may last between 30 seconds and five minutes, depending on the amount of software that needs to be loaded and conditioned. The Elgar logo will be displayed during the power up cycle.

NOTE: To prevent large inrush currents flowing while resetting the SW, allow several seconds before cycling power, especially if power is cycled via an external circuit breaker.

- ➋ **HELP KEY.** Press this key to access a help screen for the menu item currently displayed. Help screens may contain information not found in this manual.
- ➌ **ENTER KEY.** Press this key to:
 - Go to the next menu level on the LCD display
 - Enter the incr./dec. mode using the knob or arrow keys
 - Accept a numeric entry via the keypad and/or knob
 - Accept a name in text mode entry.
- ➍ **MENU KEY.** Press this key to go to the previous menu level, to abort editing a data entry field when using the numeric keypad, or to switch from remote to local mode.
- ➎ **WAVEFORM MONITOR BNCs.** Trigger output provides a synchronization pulse (see Table 3–1, SYNC). Phases A, B, and C provide scaled outputs for monitoring drive signals to output amplifiers.
- ➏ **CONTRAST KEYS.** These keys, located below the rotary knob, adjust the contrast of the display. Press and hold the left key to decrease the contrast; press and hold the right key to increase the contrast to the desired level.
- ➐ **KNOB.** Use the rotary knob for data entry and for slewing of voltage and frequency. The knob serves the same function as the **Up/Down Arrow** keys. There are three knob thresholds which increment by 0.1, 1.0, or 10.0, depending on the speed of the rotation.
- ➑ **ARROW KEYS.** The **Up** and **Down Arrow** keys allow you to move between menu selections on the currently displayed page and to increase or decrease values in the incr./dec. mode.

Left Arrow Key. This key returns to the previous menu level (a shortcut for the **Menu** key) and, in the text mode or numeric entry, acts as a backspace.

Right Arrow Key. This key moves you to the next menu level (a shortcut for the **Enter** key) and, in the text mode, accepts the current character.

- ⑨ **KEYPAD.** The 12-key keypad is used to enter numeric values (0 through 9), a decimal point (when required), and to change the polarity of the selection via the +/- key.
For example, to enter an amplitude value of “-139.2,” enter 1, 3, 9, decimal point, 2; press the +/- key to change the polarity; then press the **Enter** key to accept the value.
- ⑩ **FUNCTION KEYS F1 THROUGH F3.** Functions of these keys depend on the selected menu item, and are defined in the Help screens.
- ⑪ **OUTPUT KEY.** This key activates/deactivates the output relay. The status of the output relay is indicated as “OUTPUT [ON]” or “OUTPUT [OFF]” on the top line of the LCD display.

3.3 Menus

The backlit graphics LCD screen displays menus, data entry fields, and status information in the general format shown below.

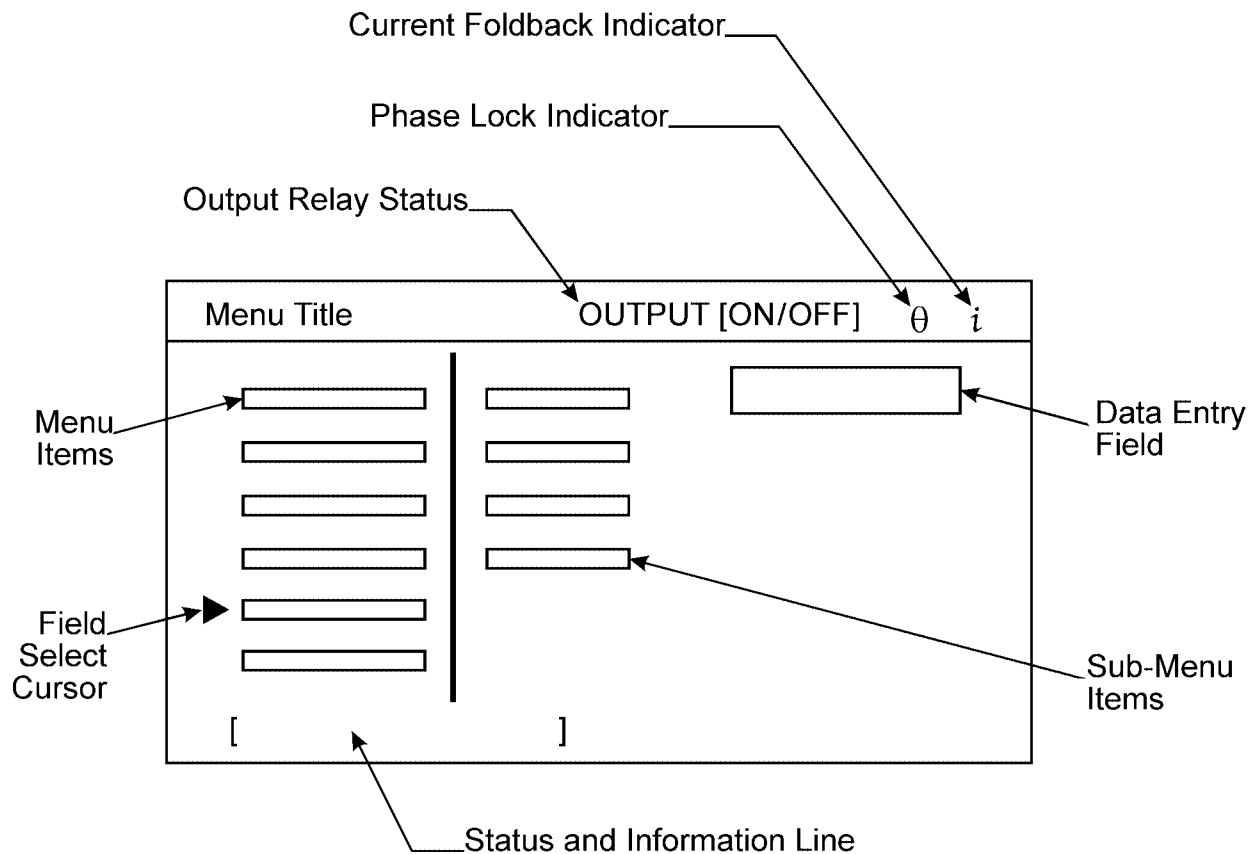

- Use the **Enter** and **Menu** keys or the **Right/Left Arrow** keys to move between the menus.
- Use the **Up/Down Arrow** keys to cycle through the items within a specific menu.
- When you select an item, you can enter data in two ways: (1) Use the keypad to type in the data, or (2) press the **Enter** key to place a box around the value area, then use the **Up/Down Arrow** keys or the **Knob** to select the data to be entered.
- Press the **Enter** key to accept the data.

3.3.1 MAIN MENU

The MAIN MENU consists of the sub-menus listed below.

MAIN MENU	OUTPUT [OFF]
PROGRAM	
MEASURE	
WAVEFORM	
SEQUENCE	
INSTR	
SYSTEM	

MAIN MENU Status and Information Data:

<u>Menu Item</u>	<u>Status and Information Line</u>
PROGRAM	[interactive programming]
MEASURE	[measurement system]
WAVEFORM	[create/edit waveform]
SEQUENCE	[create/edit sequences]
INSTR	[instrument configuration]
SYSTEM	[system configuration]

3.3.2 PROGRAM Menu

The **PROGRAM** menu allows you to:

- Select a phase
- Program amplitude–function polarity validates the amplitude input, see Section 3.4 for more information
- Program current limit, either value or level
- Program frequency–maximum frequency is determined by the selected waveforms for each phase, see Section 3.4, *Front Panel Programming Conventions*, for more information about maximum frequency
- Program phase offset (phase offset represents a phase lead)
- Select a function to be output on the selected phase.

MAIN MENU		OUTPUT [OFF]	
▶ PROGRAM	PHASE A (or B or C)		
MEASURE	AMPL	<input type="text"/>	V
WAVEFORM	CURL	<input type="text"/>	A
SEQUENCE	FREQ	<input type="text"/>	Hz
INSTR	θ ANG	<input type="text"/>	Deg
SYSTEM	FUNC	<input type="text"/>	

PROGRAM Menu Status and Information Data:

<u>Menu Item</u>	<u>Status and Information Line</u>	<u>Range/Default</u>
PHASE A	[<enter> for next phase]	Phases A, B, C
AMPL	[program output RMS/DC voltage] *	0–156 V or 0–312 V (to 0.01V resolution)
CURL	[program RMS/DC current limit]	0–16 A or 0–8 A (default: 5A)
FREQ	[program output frequency] * (default: 60 Hz)	40–63 Hz or 40–500 Hz
θ ANG	[program phase angle offset]	0–360° (default: 0°, 120°, 240°)
FUNC	[program output waveform] **	Default: Sine

- * There is only one frequency setting for all three phases. Changing the frequency of one phase changes the frequency for all phases.
- ** To operate the SW as a DC supply, select the function as “DC+” or “DC-” for positive and negative DC. “AC+DC Coupling” must also be selected from the INSTRUMENT menu. The AMPL field is programmed to 0V as a precaution when changing to or from the “DC+” or “DC-” function.

3.3.2.1 Locking Program Fields

For two- or three-phase systems, individual programming fields of amplitude, current limit, phase angle, and function may be “locked” so that any change made to phase A will be made to phases B and C. The Lock function is intended for front panel operation. When using GPIB, use the SOURCE0 command.

To lock a field:

1. Move the field select cursor to the field to be locked in the Phase A Program menu.
2. Press the **F1** function key. The “¥” symbol should appear to the right of the field indicating the lock mode is active.
3. Enter the value to be locked into the field.
NOTE: The lock will not be active until a value is entered; previously entered values are not locked.

To unlock a field:

1. Move the field select cursor to the locked field in the Phase A Program menu.
2. Press the **F1** function key. The “¥” symbol should disappear.

3.3.2.2 Front Panel Store/Recall

The current state of the SW can be saved and restored using the Front Panel Store/Recall feature. The following parameters are affected:

The current state of the Program Menu:

- Amplitude
- Current Limit
- Frequency
- Phase Angle
- Function

System External Menu:

- External Modulation
- Direct Input
- External Gain
- Flicker
- Low Frequency
- Clock/Lock

Instruction Menu:

- Range
- Coupling
- IMode
- VLIM
- Parallel Mode

System User Menu:

- Sync Out

System Configuration Menu:

- Boost

The Store/Recall Menu can be accessed by pressing **F2** from any Program menu edit field. Setups are stored/recalled as a number from 0 to 49. The incr./dec. mode is not available for this menu. Store/Recall functions do not affect the Lock/Unlock status of the Program menu fields. If a field is locked, it will remain locked. However, the Recall parameters for phases B and C will be updated.

To store a setup:

1. Press **F2** from any Program menu edit field.
2. Move the field select cursor to "STORE SETUP."
3. Enter a setup number from 0 to 49.

To recall a setup:

1. Press **F2** from any Program menu edit field.
2. Move the field select cursor to "RECALL SETUP."
3. Enter the previously stored setup number from 0 to 49.

3.3.3 MEASURE Menu

The **MEASURE** menu is unavailable on the SW 5550AE, SW 3700AE, and SW 1850AE models.

3.3.4 WAVEFORM Menu

The **WAVEFORM** menu allows you to perform a variety of actions on waveshapes and waveforms, including the creation of a new waveform based on a waveshape in memory.

The waveshapes and waveforms are limited to spikes, dropouts, sags and surges of existing waveforms in the scratchpad area. This is accomplished by loading the existing waveshape into the waveform scratchpad then editing it. The edited waveform may then be viewed, output using the SCRATCH function name in the PROGRAM menu, or saved to the waveform library.

WAVEFORM	OUTPUT [OFF]
LOAD	
EDIT	
VIEW	
SAVE	
DELETE	

3.3.4.1 LOAD Sub-Menu

The WAVEFORM menu allows you to **LOAD** an existing waveform from non-volatile or flash memory to the waveform scratchpad.

Any existing information in the scratchpad is erased when a new waveform is loaded.

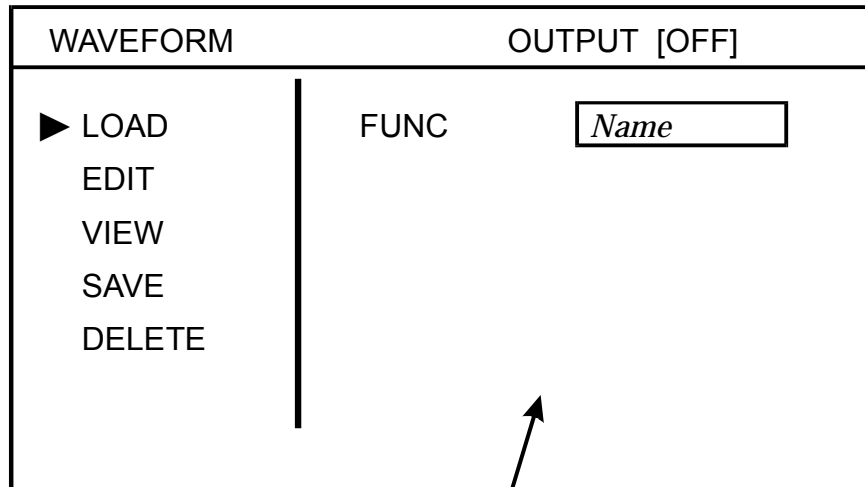

Displays library of waveforms

LOAD Sub-Menu Status and Information Line Data:

<u>Menu Item</u>	<u>Status and Information Line</u>
------------------	------------------------------------

FUNC	[<enter> to select waveform]
------	------------------------------

Press the **Up/Down Arrow** keys or use the **Knob** to scroll through the list of available waveforms. With the desired waveform in the selection window, press **<Enter>**.

3.3.4.2 EDIT Sub-Menu

The WAVEFORM menu allows you to **EDIT** a waveform in the scratchpad.

WAVEFORM		OUTPUT [OFF]	
LOAD	FREQ	<input type="text"/>	Hz
▶ EDIT	Vrms	<input type="text"/>	V
VIEW	START	<input type="text"/>	Deg
SAVE	TIME	<input type="text"/>	ms
DELETE	STOP	<input type="text"/>	Deg
	AMPL	<input type="text"/>	V

EDIT Sub-Menu Status and Information Data:

<u>Menu Item</u>	<u>Status and Information Line</u>	<u>Range</u>
FREQ	[waveform frequency]	40–63 Hz or 40–500 Hz, depending on waveform loaded
Vrms	[output waveform voltage]	0–156 or 0–312 V
START	[starting phase angle]	0–360°
TIME	[surge/sag duration]	0–1/Freq
STOP	[ending phase angle]	Start–360°
AMPL	[drop/spike voltage]	-220.6 to 220.6 V _{peak} (156 Vrms range) -441.2 to 441.2 V _{peak} (312 Vrms range)

NOTES: Vrms is in terms of RMS voltage while AMPL is in terms of peak voltage. Both of these values depend on the currently selected voltage range setting in the INSTRUMENT menu.

Maximum frequency is determined by the selected waveform; see Section 3.4, Front Panel Programming Conventions for more information about maximum frequency.

3.3.4.3 VIEW Sub-Menu

The WAVEFORM menu allows you to **VIEW** a waveform:

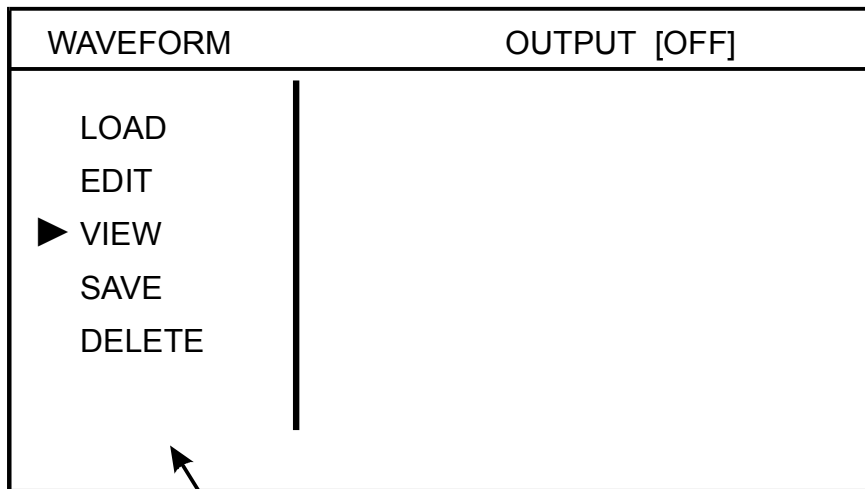

Selecting VIEW will display the waveform in the scratchpad as shown below.

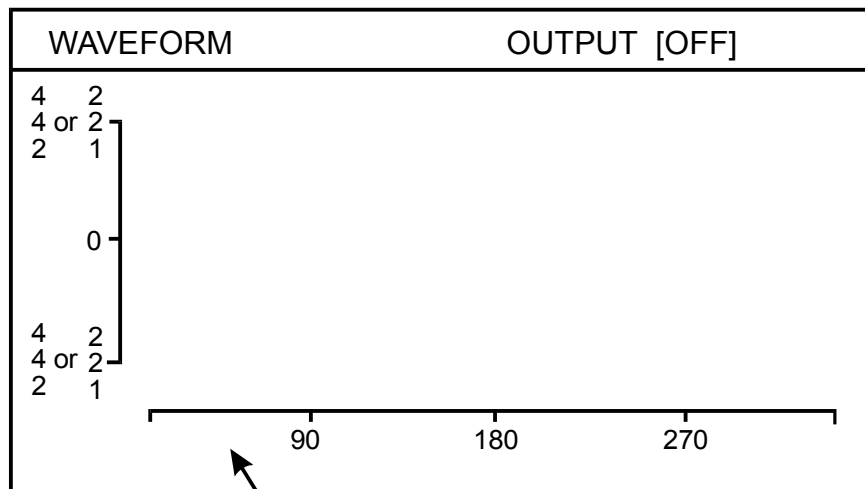

Basic display after selecting VIEW

The minimum and maximum V_{peak} values displayed on the vertical axis (either -442 to +442 or -221 to +221) are based on the selected voltage range setting in the INSTRUMENT menu.

3.3.4.4 SAVE Sub-Menu

The WAVEFORM menu allows you to assign a name to a new waveform and **SAVE** it from the scratchpad to non-volatile memory.

1. Use the **Up/Down Arrow** keys or the **Knob** to enter the custom waveform name. Press the **Right Arrow** key to proceed to the next character; press the **Left Arrow** key to backspace. The last character must be “-”.
2. Press the **Enter** key.
3. Go to SAVE or SAVE RMS and press the **Enter** key to save.

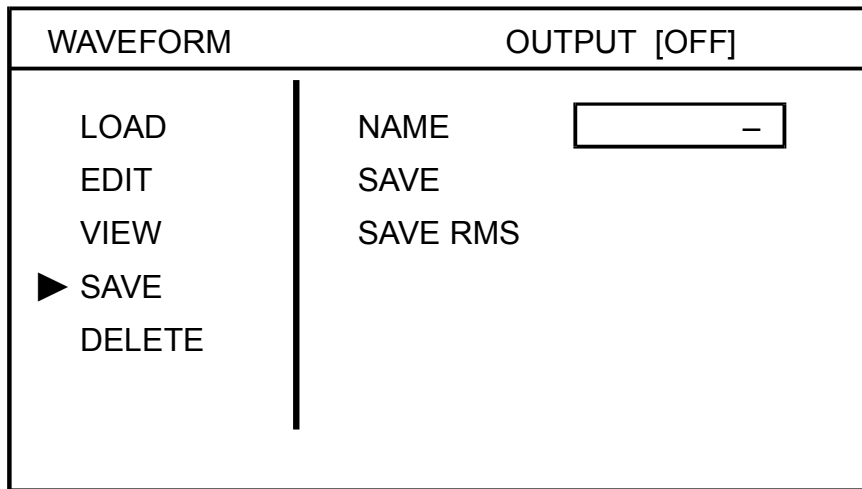

SAVE Sub-Menu Status and Information Data:

<u>Menu Item</u>	<u>Status and Information Line</u>
NAME	[-> = next char, <- = backsp]
SAVE	[save waveform to library] The waveform is scaled to maintain the RMS value of the waveform fundamental.
SAVE RMS	[save waveform to library] The waveform is scaled so that the entire waveform conforms to the Vrms value of the WAVEFORM EDIT menu Vrms field.

3.3.4.5 DELETE Sub-Menu

The WAVEFORM menu allows you to **DELETE** a waveform stored in non-volatile memory.

ALL USER WAVEFORMS - Erases the 50 user waveform locations in non-volatile RAM. Any user waveforms currently running will not be deleted.

INITIALIZE MEMORY - Resets the waveform library to the factory settings. All factory waveforms will be restored and all user waveforms stored in non-volatile RAM will be erased. You must cycle power to the unit after this function for the changes to take effect.

NOTE: Under normal operating conditions this function is not required. Instead, use "Delete-All User Waveforms."

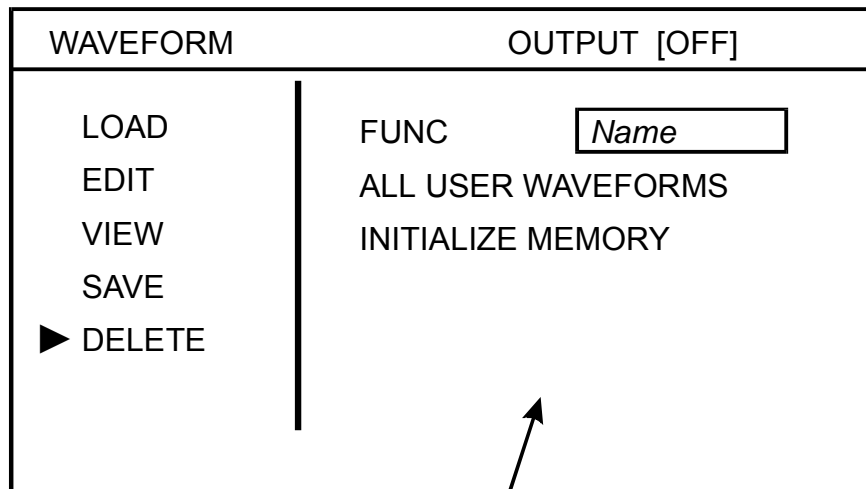

Press **Right Arrow** key to toggle custom waveforms

DELETE Sub-Menu Status and Information Data:

<u>Menu Item</u>	<u>Status and Information Line</u>
FUNC	[<enter> to select waveform]
ALL USER WAVEFORMS	[<enter> for all user waveforms]
INITIALIZE MEMORY	[Resets to factory defaults]

NOTE: If you attempt to delete a waveform in Flash Memory, the message "! - STANDARD WAVEFORM" will appear.

3.3.5 SEQUENCE Menu

The **SEQUENCE** menu allows you to create, edit, and execute a sequence.

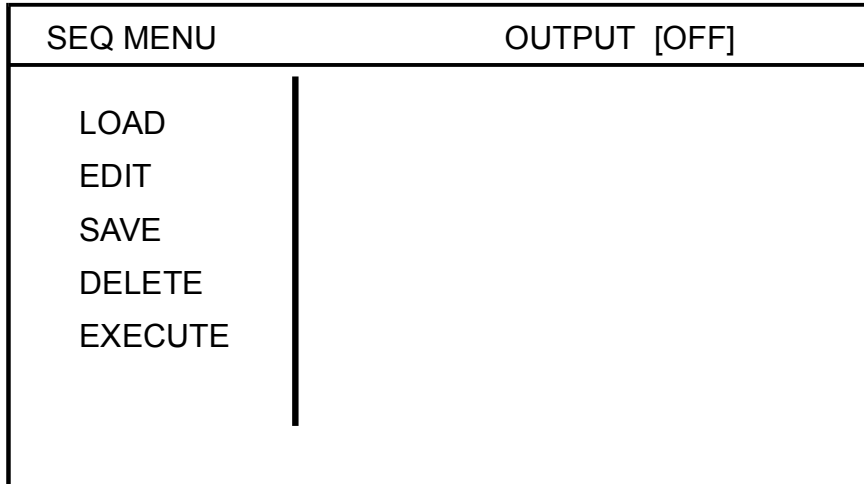

3.3.5.1 LOAD Sub-Menu

The SEQUENCE menu allows you to **LOAD** an existing sequence from non-volatile or flash memory to the sequence scratchpad.

NEW - Erases all segments in the SEQUENCE scratchpad.

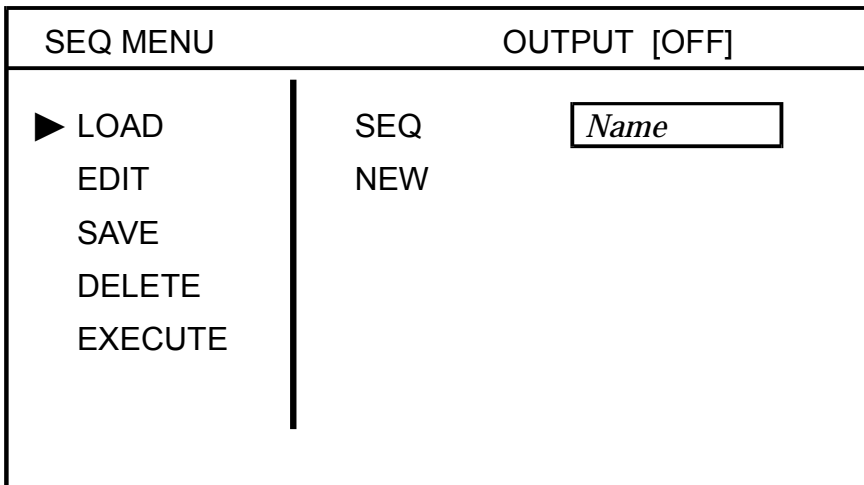

LOAD Sub-Menu Status and Information Data:

<u>Menu Item</u>	<u>Status and Information Line</u>
SEQ	[load sequence to scratchpad]
NEW	[clear sequence scratchpad]

3.3.5.2 EDIT Sub-Menu

The SEQUENCE menu allows you to **EDIT** a sequence in the scratchpad. Frequency or amplitude can be ramped over the segment duration.

SEQ EDIT		OUTPUT [OFF]		
SEG	0	FREQ	60.00	┌
CYC	0	TIME	0.00	ms
	AMPL	FUNC	θ	ANGL
A	0.00	┌	Sine	0.00
B	0.00	┌	Sine	120.00
C	0.00	┌	Sine	240.00

EDIT Sub-Menu Status and Information Line Data:

<u>Menu Item</u>	<u>Status and Information Line</u>	<u>Range</u>
SEG	[select segment number]	0–999
FREQ	[output frequency in Hz]	40–63 Hz or 40–500 Hz, depending on waveforms selected for phases A, B, and C
CYC	[# of cycles, F1 toggles SYNC]	0–9999
TIME	[segment execution time]	0–9999 ms/sec/min
AMPL	[amplitude]	0–156 or 0–312 V
FUNC	[output waveform]	—
θ ANGL	[phase θ angle (degrees)]	0–360°

The Step symbol refers to a voltage or frequency “step” in which the voltage or frequency value in the current segment immediately steps to the specified value. By moving the field select cursor to the Step symbol and pressing <Enter>, the **Up/Down Arrow** keys can be used to change the Step signal to the Ramp symbol to indicate a voltage or frequency ramp.

When Ramp is selected, the values in the current segment are the starting values of the ramp. The voltage or frequency values of the next segment are the ending values of

the ramp. The SW will calculate an even number of voltage or frequency steps, over the time period of the current segment (value specified in the Time field), to reach the values specified in the following segment.

- A ramp must always consist of at least two segments so that starting and ending values can be specified.
- Ramps can be increasing or decreasing in value.
- Voltage ramping for Phase A, Phase B, Phase C, and Frequency are all independently controlled and can be run in any combination. For example, Phase A could be ramping a Sine wave from 0 to 120 VAC, Phase B could be ramping from 28 to 0 VDC, Phase C could be a steady 230 VAC Square wave, and the Frequency could be ramping from 50 Hz to 400 Hz - all at the same time.
- Phase angles cannot use the ramping function.
- Ramp steps occur in increments of the period specified in the FREQ field. If FREQ is 60 Hz, steps occur at 16.67 ms intervals. If the FREQ field is 500 Hz, updates occur at 200 μ s intervals. For DC ramping, use the highest frequency (500 Hz) to make the ramp as smooth as possible.
- If the specified ramp time is less than one period, one period will be used.

Function keys F1 through F3 are required to create and edit sequences. These keys are dependent on the field select cursor position and are defined as follows:

The “SEG” Edit Field

The SEG edit field is used to move through the segment list and accept integer values from 0 to 99. Since a Sequence is made up of a continuous list of segments, segments must be created in sequential order. When the Sequence scratchpad is initialized, only a single segment is available for editing. Trying to access segments other than segment 0 will result in an “end of sequence” error message. An existing segment number can be entered directly into the SEG field, or you can select the SEG field by pressing the **Enter** key, then use the **Arrows** or the **Knob** to scroll through all existing segments.

The function keys are used to insert, delete or copy segments:

- F1** Inserts a new segment in the position immediately following the current segment. The new segment number will be one greater than the currently displayed segment. The Segment edit field will be automatically updated to display the newly created segment.
- F2** Deletes the currently displayed segment.
- F3** Copies the previous segment information to the currently displayed segment.

The “CYCLES” Edit Field

When the field select cursor is at the CYCLES field, pressing **F1** will toggle the SYNC SELECT symbol “*”. This is a flag used in conjunction with the SYNC field of the Sequence Execute menu; if SYNC is set to **SELECT SEG**, only those segments that are enabled will generate a sync signal at the front panel BNC connector. If SYNC is set to **EVERY SEG**, every segment will generate a sync signal.

NOTE: The CYC field has a maximum input and display range of 9999. For FREQ and TIME combinations that exceed 9999 cycles, the CYC field will still indicate 9999. This limitation does not apply to GPIB control.

The “FREQ” Edit Field

The acceptable range of frequency is determined by the waveforms selected for Phases A, B, and C.

The “AMPL” Edit Field

For information about the relationship between AMPL and FUNC, refer to Section 3.4, *Front Panel Programming Conventions*.

3.3.5.3 SAVE Sub-Menu

The SEQUENCE menu allows you to assign a name to a new sequence and **SAVE** it from the scratchpad to non-volatile memory.

1. Use the **Up/Down Arrow** keys or the **Knob** to enter the custom waveform name. Press the **Right Arrow** key to proceed to the next character; press the **Left Arrow** key to backspace. The last character should be “-”.
2. Press the **Enter** key.
3. Go to SAVE and press the **Enter** key again to save.

SEQ MENU	OUTPUT [OFF]
LOAD EDIT ► SAVE DELETE EXECUTE	NAME <input style="width: 100px;" type="text" value="-"/> SAVE

NOTE: You can save up to 100 sequences, consisting of up to 1000 segments total. Once you have reached this maximum, you must delete a previously saved sequence in order to save a new one.

SAVE Sub-Menu Status and Information Data:

<u>Menu Item</u>	<u>Status and Information Line</u>
NAME	[-> = next char, <- = backsp]
SAVE	[store sequence in library]

3.3.5.4 DELETE Sub-Menu

The SEQUENCE menu allows you to **DELETE** a sequence stored in non-volatile memory.

ALL USER SEQUENCES - Erases all user sequence locations in non-volatile RAM.

INITIALIZE MEMORY - Resets the sequence library to the factory settings. All factory sequences will be restored and all user sequences stored in non-volatile RAM will be erased. Cycle power to the unit after this function for the changes to take effect.

NOTE: Under normal operating conditions this function is not required. Instead, use "Delete-All User Sequences."

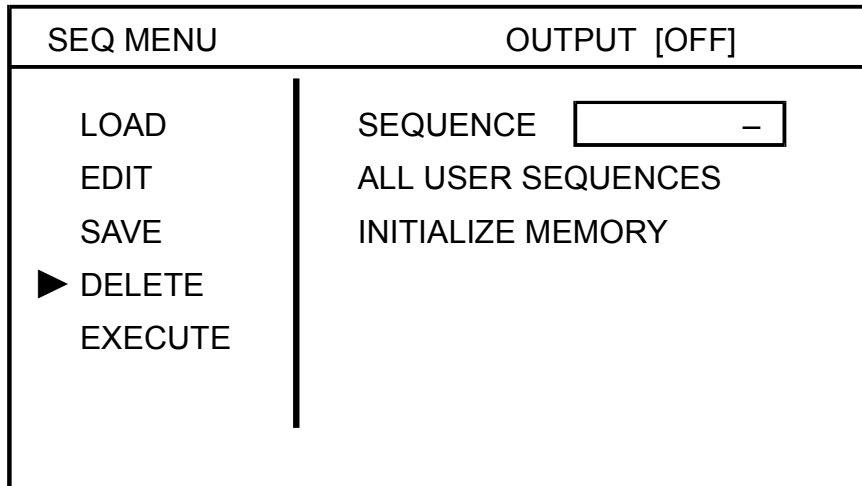

DELETE Sub-Menu Status and Information Data:

<u>Menu Item</u>	<u>Status and Information Line</u>
SEQUENCE	[delete stored sequence]
ALL USER SEQUENCES	[delete all user sequences]
INITIALIZE MEMORY	[reset to factory defaults]

3.3.5.5 EXECUTE Sub-Menu

The SEQUENCE **EXECUTE** sub-menu allows the selection of the start, run, and stop modes of a sequence. The front panel operation is defined here, but all modes are also available via the GPIB. A sequence can be executed in any combination of the following modes:

- A sequence can be run in its entirety, or stepped through one segment at a time. When in this “step” mode, the most recent segment can be repeated.
- A sequence can be executed only once, or looped until the STOP command is received.
- A sequence can be terminated with the outputs automatically programmed to 0 volts, restored to the waveforms and values before the sequence began, or remain at the waveforms and values of the last segment in the sequence. The last two options will occur with no interruption in output power.

The SEQUENCE EXECUTE sub-menu selections are explained in Table 3–1.

SEQ MENU	OUTPUT [OFF]
LOAD	LOAD SEQ <input type="text" value="Name"/>
EDIT	SYNC SELECT SEG
SAVE	CONTROL STOP
DELETE	RUN MODE LOOP
▶ EXECUTE	STOP MODE ZERO
	LOOP CNT 1

EXECUTE Sub-Menu Status and Information Data:

<u>Menu Item</u>	<u>Status and Information Line</u>	<u>Range</u>
LOAD SEQ	[<enter> to select sequence]	—
SYNC	[sync output configuration]	Select Seg/Every Seg
CONTROL	[start/stop sequence]	Run/Step/Stop
RUN MODE	[execute seg once or repeat]	Repeat/Single/Loop
STOP MODE	[restore output on seg stop]	Zero/Program/End Seg
LOOP COUNT	[loop execution count]	1–9999

SELECTION	PURPOSE
LOAD SEQ	Loads a sequence from the sequence library or the sequence scratchpad. When running under GPIB control, the Event Status Register and serial polling can be used to indicate when the sequence loading is complete. The front panel display will indicate "Processing sequence..." while loading, and "Sequence loaded" when complete.
SYNC	Configures the SYNC Trigger output to generate a pulse for every segment or only selected segments. When SYNC selection is changed, you must reload the sequence.
CONTROL	<p>Used to start a sequence, stop a sequence, or start a sequence in the STEP mode. A sequence must be loaded before RUN or STEP can be selected. All operations have an immediate effect.</p> <p>RUN – Run the previously loaded sequence. A sequence does not need to be reloaded when switching between RUN, STEP or STOP. The sequence will begin executing immediately after a RUN or STEP command.</p> <p>STEP – Step through the previously loaded sequence. Each segment will execute and remain at the value of the last cycle until instructed to execute the next segment, or repeat the current segment. When stepping through a sequence under front panel control, the F1 function key is used to execute the next segment, and the F2 key is used to repeat the current segment.</p> <p>STOP – Stops the active sequence.</p>
RUN MODE	<p>Specifies the running mode of the sequence. This parameter takes effect once a sequence has begun.</p> <p>REPEAT – Repeats sequence until a STOP command is received.</p> <p>SINGLE – Executes the sequence only once, then returns to the operation specified in the STOP MODE field.</p>
STOP MODE	<p>Specifies the mode of operation when a sequence is terminated. This can occur when running in the SINGLE execution mode, or when STOP is selected.</p> <p>ZERO – Programs the outputs to 0 volts when the sequence is terminated.</p> <p>PROGRAM – The outputs are restored to the waveforms and values in the Program Menu. This mode can be used for a continuous output between sequences. The Program Menu cannot be modified while a sequence is running. When this mode is selected, set BOOST to OFF (see System menu).</p> <p>END SEG – The outputs will remain at the waveforms and values of the last segment in the sequence.</p>

Table 3–1 Sequence Execute Menu

3.3.6 INSTR (Instrument) Menu

The **INSTR** menu allows you to:

- Set the output range (156 or 312 volts).
- Select either AC or AC+DC coupling.
- Select the peak overvoltage limit.
- Select shutdown, foldback, or time-out mode (foldback for the time specified in the ITIMO field then shutdown mode).
- Select the time for the time-out mode.
- Select amplifier parallel operation. When the Parallel mode is ON, only Phase A will appear in the Program menu. Rear panel output power wiring must match the Parallel mode selection.



CAUTION! Parallel mode must match the rear panel output wiring before programming output amplitude.

MAIN MENU		OUTPUT [OFF]	
PROGRAM	RANGE		<input type="text"/>
MEASURE	COUPLING		<input type="text"/>
WAVEFORM	I MODE		<input type="text"/>
SEQUENCE	I TIMO		<input type="text"/>
▶ INSTR	V_LIM		<input type="text"/>
SYSTEM	PARALLEL		<input type="text"/>

INSTR Menu Status and Information Data:

<u>Menu Item</u>	<u>Status and Information Line</u>	<u>Range</u>
RANGE	[156V or 312V range]	156V / 312V
COUPLING	[AC or AC+DC coupling]	AC / AC+DC
I MODE	[supervisory current mode]	Shutdown / Foldback / Time-Out
I TIMO	[current limit time-out]	Constant timed / 0–9999 ms
V_LIM	[peak voltage limit]	20–255 / 40–510
PARALLEL	[parallel output amplifiers]	On / Off

3.3.7 SYSTEM Menu

3.3.7.1 USER Sub-Menu

The SYSTEM **USER** sub-menu allows you to:

- Configure power up values.
- Execute the unit’s self-test.
- Enable/disable hint messages.
- Enable/disable the sync output in the Program mode (i.e., when a sequence is not running).

SYSTEM	OUTPUT [OFF]
▶ USER	SAVE SYSTEM CONFIG
COMM	RESTORE DEFAULTS
EXTERNAL	HINT MESSAGE ON
FAULTS	SELF-TEST 0000
CONFIG	SYNC OUT ON

USER Sub-Menu Status and Information Data:

<u>Menu Item</u>	<u>Status and Information Line</u>
SAVE SYSTEM CONFIG	[store new power-up setting]
RESTORE DEFAULTS	[factory power-up defaults]
HINT MESSAGE	[hint messages on/off]
SELF-TEST	[execute self-test]
SYNC OUT	[sync output on/off/event]

SAVE SYSTEM CONFIG saves the current system configuration of the Program and Instrument menus and initializes the SW to these settings on power up.

RESTORE DEFAULTS resets the power up configuration to factory defaults.

SYNC OUT selects the output sync signal to ON, OFF or EVENT. In the **ON** position, the signal is driven by the output frequency of the waveform, or sequence settings. In the **EVENT** position, a pulse will be generated for any change in VOLT, CURR, FREQ, PHASE, or WAVEFORM.

The **SYNC OUT** setting only affects normal (non-sequence) mode. To set up the SW so that a sync pulse only occurs for a specified sequence segment, set this parameter to OFF. That way, before and after a sequence is run, no other sync pulses will occur.

Table 3–2 provides self-test result definitions.

BIT	MEANING	BIT	MEANING
0001	LCD Test	0100	Battery Test
0002	EPROM CKSUM	0200	QSPI Test
0004	NVRAM BANK 0 CKSUM	0400	DFI Test
0008	NVRAM BANK 1 CKSUM	0800	Speaker Test
0010	RAM Test	1000	DWSB Self-Test 0
0020	VXI Test	2000	DWSB Self-Test 1
0040	QSCI Test	4000	IWGB Self-Test 0
0080	GPIB Test	8000	IWGB Self-Test 1

Table 3–2 SELF-TEST Results Definitions

3.3.7.2 COMM Sub-Menu

The SYSTEM **COMM** (Communications) sub-menu allows you to:

- Configure the GPIB address and display remote status.
- Display firmware version information.

SYSTEM	OUTPUT [OFF]	
USER	GPIB ADDR	25
▶ COMM	ECDI VER	X.XX
EXTERNAL	DWSB VER	X.XX
	IWG VER	X.XX
FAULTS	BAUD RATE	57600
CONFIG	DWSB	ON-LINE
	IWGB	ON-LINE

The DWSB and IWGB fields indicate the internal communication status of the Digital Waveform Synthesis board and Interharmonic Waveform Generator board. These should always indicate **ON-LINE** unless a failure has occurred.

COMM Sub-Menu Status and Information Data:

<u>Menu Item</u>	<u>Status and Information Line</u>	<u>Range/Default Value</u>
GPIB ADDR	[select gpib address]	Range 1–30 Default 25
ECDI VER X.XX DWSB VER X.XX IWG VER X.XX	[installed firmware version]	—
BAUD RATE	[RS-232 Baud Rate]	Range 300–57600 Range 1200–57600 Default 57600
DWSB	[Digital waveform status]	On-Line/Off-Line
IWGB	[Interharmonic Wfrm Gen stat]	On-Line/Off-Line

3.3.7.3 EXTERNAL Sub-Menu

The SYSTEM **EXTERNAL** sub-menu allows you to:

- Select external modes of operation (Direct Input, External Modulation, External Gain, and Clock/Lock).
- Select Flicker mode (reference impedance).
- Select Low Frequency ON to disable the RMS Voltage Servo (normal IEC test mode).



CAUTION! Damage to the equipment may occur if input frequency requirements are violated (DC, 40–500 Hz).

Refer to Table 2–3 for external analog inputs (EXTA, EXTB, EXTC). Table 3–3 provides additional data on the External sub-menu.

SYSTEM	OUTPUT [OFF]	
USER	EXT MOD	OFF
COMM	DIR INPUT	OFF
▶ EXTERNAL	EXT GAIN	OFF
FAULTS	FLICKER	OFF
CONFIG	LOW FREQ	ON
	CLOCK/LOCK	OUT

EXTERNAL Sub-Menu Status and Information Data:

<u>Menu Item</u>	<u>Status and Information Line</u>	<u>Range</u>
EXT MOD	[external modulation]	On / Off
DIR INPUT	[external direct input]	On / Off
EXT GAIN	[external gain control]	On / Off
FLICKER	[reference impedance]	On / Off
LOW FREQ	[on = normal IEC test mode]	On / Off
CLOCK/LOCK	[clock lock enable/disable]	In / Out / Off

SELECTION	PURPOSE
EXT MOD (External Amplitude Modulation)	Amplitude modulation of an output waveform is possible via an input signal from the rear panel. Input of 0-5 Vrms corresponds to a 0-20% modulation. To allow for the modulation voltage, the maximum programmed voltage is 130 Vrms in low range, and 260 Vrms in high range.
DIR INPUT (External Direct Input)	Input on rear panel allows reference signal to go directly to amplifiers. A signal of 0–5 Vrms (± 7.07 Vpeak) or ± 5 VDC corresponds to 0 to full scale programmed voltage output. CAUTION: Do not exceed the maximum frequency specifications listed in Section 4.
EXT GAIN (External Gain)	Input on rear panel is used to scale output waveform. A 0 to ± 7.07 VDC input signal corresponds to 0 to \pm full scale programmed voltage output.
FLICKER (Source Impedance)	This option selects IEC 725 reference impedance ($0.40+j0.25$) Ω .
LOW FREQ (Low Frequency)	This option should be used for external AC input signals between DC and 40 Hz (the maximum VA rating must be derated). Also, use for IEC 1000-3-2 and IEC 1000-3-3 testing. The RMS servo is bypassed. As a result, load regulation is a function of output impedance, and RMS current limit (voltage foldback) is disabled.
CLOCK/LOCK	Use this option to configure rear panel clock/lock signal as input or output. When configured as input, the power outputs will attempt to sync to clock/lock input frequency. Target output frequency is determined by frequency value entered in Program Menu FREQ field. Target frequency should be entered before clock/lock is configured as output. Input configuration process is as follows: <ol style="list-style-type: none"> 1. Enter target frequency in Program Menu FREQ field. 2. Go to System External Menu and enable CLOCK/LOCK option by selecting IN. 3. The unit will now attempt to lock to the input signal; this process can take up to 5 seconds. Phase lock is indicated on the LCD by the θ symbol to the right of the OUTPUT [ON/OFF] status. Output relay is not allowed to close until phase lock has been established. 4. Close the output relay. 5. Clock/lock input frequency is continually compared to the target frequency. If input frequency changed more than $\pm 10\%$, output relay will open and an error message will be displayed. <p>When configured as an output, clock/lock signal outputs a square wave of the same frequency as the power outputs. Select OFF to disable. OFF will configure clock/lock as an input with the PLL mode disabled.</p>

Table 3–3 System External Menu

3.3.7.4 FAULTS Sub-Menu

Pressing <Enter> to select FAULTS will display a list of logged fault conditions LOG1 through LOG6. These are three 8-bit registers used to troubleshoot errors that cause the system to shut down. Fault register definitions are available through the Help screens of the SmartWave unit.

SYSTEM	OUTPUT [OFF]		
USER	FR1	FR2	FR3
COMM	LOG1: 00	00	00
EXTERNAL	LOG2: 00	00	00
▶ FAULTS	LOG3: 00	00	00
CONFIG	LOG4: 00	00	00
	LOG5: 00	00	00
	LOG6: 00	00	00

Fault History

The SYSTEM **FAULTS** sub-menu menu displays the last six shutdown faults in hexadecimal. All three fault registers are displayed with LOG1 as the most recent fault and LOG6 the oldest.

Register bit definitions are shown in Table 3–4. Fault descriptions are shown in Table 3–5 through Table 3–7.

FAULT REGISTER 1		FAULT REGISTER 2		FAULT REGISTER 3	
8_	—	8_	—	8_	RLY156
4_	—	4_	—	4_	RLY312
2_	F3:OV	2_	F4:OT	2_	—
1_	DC_ERR	1_	F2:OV	1_	—
_8	ROV	_8	UV	_8	—
_4	OC	_4	ROC	_4	—
_2	48VLOW	_2	RMS_OV	_2	—
_1	GND_FLT	_1	FLT_IN	_1	RLY_FLT

Example: **FR3 70**: RLY156 and RLY_FLT

Table 3–4 Fault Register Bit Definitions

Although the DFI Fault is not included in the fault history log, any of the faults will cause a DFI error to occur. When a DFI fault is tripped, either because one of the faults above or a fault external to the SW, the output relay is opened, VPROGRAM is set to zero, and an error message is displayed.

FAULT REGISTER 1	
F3_OV	Indicates that the internal DC bus has pumped up to a hazardous level (due to sinking power rather than sourcing, i.e., attempting to discharge quickly, discharge a very large capacitor into the SW output too quickly). <u>Action:</u> SW system opens relays and shuts off.
DC_ERR	Indicates that an unacceptable level of DC voltage is present in the output when the AC coupling is selected (i.e., a waveform with DC content was selected when AC coupling was active). <u>Action:</u> SW system opens relays and shuts off.
ROV	SW output exceeded programmed VLIMIT value. <u>Action:</u> Opens relay and sets VPROGRAM to zero; displays error message.
OC	SW output current reached IPROGRAM value. <u>Action 1:</u> Limit Mode: folds back voltage to maintain constant current; displays i in right-hand corner. <u>Action 2:</u> Shutdown Mode: opens relays and displays error message. <u>Action 3:</u> Time-Out Mode: Constant current for a specified time, then opens relay and displays error message.
48V_LOW	Monitors internal housekeeping supply. <u>Action:</u> Shuts off SW system.
GND_FAULT	Monitors output neutral. <u>Action:</u> If greater than ± 20 volts with reference to chassis ground, opens relays and displays error message.

Table 3–5 Fault Description and Action (FR1)

FAULT REGISTER 2	
F4:OT	Monitors power stage heat sink temperatures. <u>Action</u> : Opens relays, displays error message for 30 seconds, then shuts off SW system.
F2_OV	Indicates that the internal DC bus has pumped up to an unacceptable level (due to sinking power rather than sourcing, i.e., attempting to discharge a very large capacitor into the SW output too quickly). <u>Action</u> : SW system tristates output amplifier until bus level becomes normal.
UV	Undervoltage: Indicates that the output voltage is less than the programmed value, but not in the voltage foldback mode. <u>Action</u> : Opens relays and displays error message.
ROC	Redundant Over Current: The RMS value of the output current has exceeded the maximum capacity of the SW. <u>Action</u> : Opens relays and displays error message.
RMS_OV	Monitors the external input in the “External Direct” mode to ensure that it does not exceed 5.2 VRMS. <u>Action</u> : Opens relays, displays error message, and sets VPROGRAM to zero volts.
FLT_IN	Fault-Input from Slave chassis: Represents the logical OR of several faults. <u>Action</u> : Opens relays; displays error message. Clearing the error message sends a fault reset to the Slave chassis. The particular Slave chassis that had the fault will then extinguish its fault indicator.

Table 3–6 Fault Description and Action (FR2)

FAULT REGISTER 3	
RLY156,RLY312	Used for internal monitoring only.
RLY_FLT	The open relay did not respond to the open/close command within 500 mSec. <u>Action</u> : Programs the output to zero and attempts to change relay state; displays error message. If unable to clear error message, a hazardous condition may exist. Use caution; voltage may be present at the output terminals.

Table 3–7 Fault Description and Action (FR3)

3.3.7.5 CONFIG Sub-Menu

Pressing <Enter> to select CONFIG will display the System Configuration options.

BOOST - Allows the Servo Boost circuit to be disabled during non-sequence operation. This option should be set to OFF when:

- The RMS Servo is ON (Low Frequency = OFF) *and*
- Sequence mode is being used with Exit mode set to “Program Menu.”

RESET CAL – Resets calibration constants to default values. Enter a confirmation code (2096) to activate this option. If you enter an incorrect code, the unit will beep and the message “! INCORRECT RESET CODE” will be displayed, the code will be reset to 0, and no changes will occur to the calibration constants.

T&MB OPT – Displays firmware configuration for the Test & Measurement option. ON indicates the Test & Measurement board is installed; OFF indicates it is not. This field is for display purposes only.

SWAE OPT – Displays firmware configuration for the Low Impedance option. ON indicates the Low Impedance hardware is installed; OFF indicates it is not. This field is for display purposes only.

SYSTEM	OUTPUT [OFF]
USER	BOOST ON
COMM	RESET CAL 0
EXTERNAL	T&MB OPT OFF
FAULTS	SWAE OPT ON
▶ CONFIG	

CONFIG Sub-Menu Status and Information Data:

<u>Menu Item</u>	<u>Status and Information Line</u>
BOOST	[System boost enable/disable]
RESET CAL	[Resets ALL. Must enter code]
T&MB OPT	[T&MB board installed?]
SWAE OPT	[IWG board installed?]

3.4 Front Panel Programming Conventions

- When programming an amplitude in the Program Menu, Sequence Edit Menu, or remotely over the GPIB, the Amplitude field is checked against the Function (Waveform) field for positive or negative amplitude; that is, the function polarity is used to validate the amplitude input value. For example, programming -100V when a DC+ waveform is selected will result in an execution error.

The polarity check has the following rules:

- Negative amplitudes cannot be input for positive functions.
 - Positive amplitudes cannot be input for negative functions.
 - If the amplitude of a phase is positive, selecting a negative polarity function will set the amplitude to zero.
 - If the amplitude of a phase is negative, selecting a positive polarity function will set the amplitude to zero.
- Phases A, B, and C will be of the same frequency. A frequency change of any phase will affect the output frequency of all phases. The frequency field is available in all three programming screens as a convenience.

The maximum allowable frequency in both the Program Menu and the Sequence Edit Menu is directly related to the waveforms selected in the FUNC fields of all three phases. Some waveforms, such as Sine, have a maximum frequency limit of 500 Hz. Others, such as Taylor, have a maximum frequency limit of 63 Hz. Since all phases must operate at the same frequency, a Taylor waveform on Phase A with a maximum frequency of 63 Hz will limit a Sine waveform on Phase C to the same 63 Hz value.

For a list of factory-provided waveforms and their maximum frequencies, refer to Section 4, *Standard Waveforms*.

- A sequence can be run on one, two, or all three phases. Two different sequences cannot be run on two phases simultaneously.
- A sequence setting will take priority over continuous settings. When a sequence is terminated, all programming AMPL values are set to zero (when STOP MODE is set to zero in the SEQUENCE EXECUTE sub-menu).

3.5 Front Panel Programming Exercise

The following example illustrates programming the SW for a voltage dropout on a 120V sine waveform that starts at 45° with a duration of 1 millisecond and an amplitude of 10 volts.

MAIN MENU	OUTPUT [OFF]
PROGRAM	
MEASURE	
WAVEFORM	
SEQUENCE	
INSTR	
SYSTEM	

1. At the MAIN MENU, select the **WAVEFORM** menu, then press <Enter>.

WAVEFORM	OUTPUT [OFF]
LOAD	
EDIT	
VIEW	
SAVE	
DELETE	

2. The WAVEFORM Menu will default to the LOAD sub-menu. If the cursor is not pointing to LOAD, use the Knob or Up/Down Arrow keys to select **LOAD**.
3. Press the **Enter** key to enter the **FUNC** (function) mode.
4. Press <Enter> again to place a box around the waveshape selection.

- Use the Knob to cycle through the waveshape selections until **SINE** appears in the FUNC box.

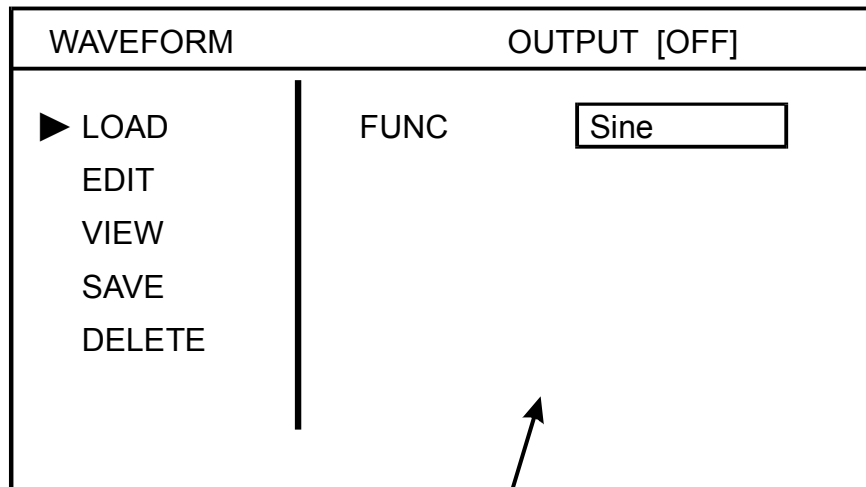

Displays library of waveforms

- Press **<Enter>** to load the sine waveshape into scratchpad memory. The message, [waveform successfully loaded], will indicate that the waveform is now in scratchpad memory.
- Press **<Menu>** to return to the WAVEFORM Menu.
- Use either the Knob or the Up/Down Arrow keys to select the **EDIT** sub-menu, then either press **<Enter>** or the **Right Arrow** key. The EDIT menu will be displayed.

WAVEFORM		OUTPUT [OFF]		
LOAD	FREQ	60.00	Hz	
▶ EDIT	Vrms	120.00	V	
VIEW	START	45.00	Deg	
SAVE	TIME	1.00	ms	
DELETE	STOP	66.60	Deg	
	AMPL	10.00	V	

9. Select **Vrms**. Enter **120**, then press **<Enter>** to set the RMS voltage to 120 volts.
10. Select **START**. Using the Keypad, enter **45**, then press **<Enter>** to set the starting phase angle to 45°.
11. Select **TIME**, enter **1** for a duration of 1 millisecond, then press **<Enter>**. Note that the instrument automatically calculates the **STOP** phase angle value (in this case, 66.6°).
12. Select **AMPL**, enter **10** for 10 volts, then press **<Enter>**.
13. Press **<Menu>** to return to the WAVEFORM Menu.

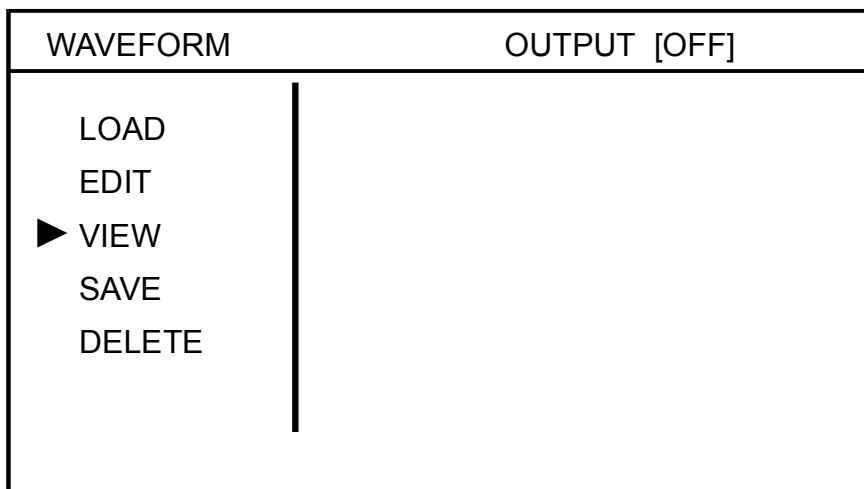

14. Select **VIEW** to view the scratchpad, then press **<Enter>**. A waveshape similar to the one illustrated below should be displayed on the scratchpad.

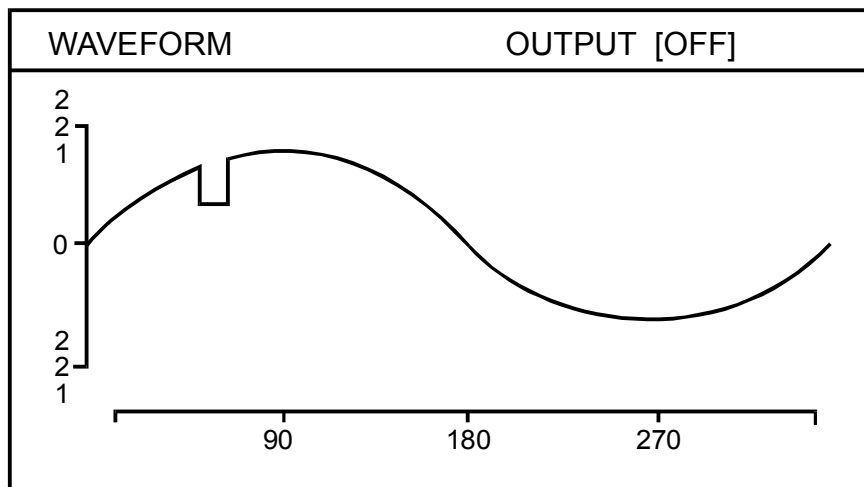

15. To retain the waveshape and display it on Phase A of the oscilloscope:
 - a. Return to the MAIN MENU by pressing <Menu> twice.
 - b. Select the **PROGRAM** Menu, then press <Enter>.

MAIN MENU		OUTPUT [OFF]		
▶ PROGRAM	PHASE A			
MEASURE	AMPL	120.00	V	
WAVEFORM	CURL	5.00	A	
SEQUENCE	FREQ	60.00	Hz	
INSTR	θ ANG	0.00	Deg	
SYSTEM	FUNC	SCRATCH		

16. In the PHASE A sub-menu:
 - a. Select **FUNC** with the Knob, then press <Enter> to place a box around the waveshape selection.
 - b. Rotate the Knob until **SCRATCH** is displayed, then press <Enter>. The scratchpad waveform will now be displayed on Phase A of the oscilloscope.
17. Press <Menu> or the **Left Arrow** key to return to the MAIN MENU.

3.6 SCPI Specification

Refer to the *SmartWave™ Switching Amplifier SCPI Programming Manual* (Elgar Document No. M162000-03).

SECTION 4

STANDARD WAVEFORMS

The following standard waveforms are provided in the SW Series:

NAME	DESCRIPTION	SCALE FACTOR	FREQUENCY RANGE
DC+	Used to operate the SW as a positive DC source (true rms)	0.7071	40-500 Hz
DC-	Used to operate the SW as a negative DC source (true rms)	0.7071	40-500 Hz
DcRip03+	+DC with 3% ripple. Frequency of the ripple is determined by the programmed output frequency (true rms)	0.7071	40-500 Hz
DcRip03-	-DC with 3% ripple. Frequency of the ripple is determined by the programmed output frequency (true rms)	0.7071	40-500 Hz
DcRip10+	+DC with 10% ripple. Frequency of the ripple is determined by the programmed output frequency (true rms)	0.7071	40-500 Hz
DcRip10-	-DC with 10% ripple. Frequency of the ripple is determined by the programmed output frequency (true rms)	0.7071	40-500 Hz
ExtrnDir	DC for use with System External direct input	1.0	40-500 Hz
FlatTp05	Flat-top sine wave with 5% distortion (true rms)	0.9344	40-63 Hz
FlatTp10	Flat-top sine wave with 10% distortion (true rms)	0.8894	40-63 Hz
Four3	Fourier square wave with 1st and 3rd harmonics (true rms)	0.8946	40-63 Hz
Four5	Fourier square wave with 1st, 3rd and 5th harmonics (true rms)	0.8703	40-63 Hz

NAME	DESCRIPTION	SCALE FACTOR	FREQUENCY RANGE
Four7	Fourier square wave with 1st, 3rd, 5th and 7th harmonics (true rms)	0.8595	40-63 Hz
Four9	Fourier square wave with 1st, 3rd, 5th, 7th and 9th harmonics (true rms)	0.8537	40-63 Hz
Scratch	Waveform scratchpad. This is the waveform edit work area. Waveforms being edited can be output for testing purposes before they are saved to non-volatile memory.	1.0	Maximum of waveform loaded
SinDc01+	Sine wave with +1% DC offset	1.0	40-500 Hz
SinDc01-	Sine wave with - 1% DC offset	1.0	40-500 Hz
SinDc10+	Sine wave with +10% DC offset	1.0	40-500 Hz
SinDc10-	Sine wave with - 10% DC offset	1.0	40-500 Hz
SinDc20+	Sine wave with +20% DC offset	1.0	40-500 Hz
SinDc20-	Sine wave with - 20% DC offset	1.0	40-500 Hz
SinDc50+	Sine wave with +50% DC offset	1.0	40-500 Hz
SinDc50-	Sine wave with - 50% DC offset	1.0	40-500 Hz
Sine	Sine wave (true rms)	1.0	40-500 Hz
Taylor	5th harmonic Taylor series wave (true rms)	0.9136	40-63 Hz
Triangle	Triangle wave (true rms)	1.2246	40-63 Hz